



Code of Practice for Operators of Quarry Delivery Vehicles

(EMPLOYING 3 OR LESS)





Our vision:

A national culture where all commit to safe and healthy workplaces and the safe and sustainable management of chemicals

Contents

Foreword	3
Acknowledgements	4

Part 1: Code of Practice

1. Introduction	5
2. Scope of Code of Practice	6
3. How to Use the Code of Practice	7
4. Definitions	9
5. Legislation	10
6. Common Hazards	13
7. The Driver	21
8. The Vehicle	24
9. The Journey	30
10. Safe Systems of Work	31

Part 2: Risk Assessment Document for Transport Operators with 3 or less Employees

Transport Operator's Details	37
Form of Undertaking	38
Emergency Telephone Numbers	39
Section A: General Requirements	40
Section B: Servicing, Maintenance and Repair	43
Section C: Working Alone and Communication	44
Section D: Slips, Trips and Falls	45
Section E: Training	47
Section F: Health	48

Contents

Part 3: Vehicle Specific-Safe Systems of Work and Risk Assessments

Introduction	49
Section (a): Tipper Vehicle	50
Section (b): Articulated Vehicle	55
Section (c): Bulk Cement Vehicle	58
Section (d): Mortar Silo	63
Section (e): Concrete Mixers	68
Section (f): Block Delivery Truck	74
Section (g): Truck Mounted Cranes	78
Section (h): Blacktop Rigid Vehicle	82
Section (i): Bitumen Tanker Vehicle	86
Section (j): Precast Concrete Delivery	92
Section (k): Small Precast Products	97
Section (l): Demountable Forklift Trucks	101
Section (m): Concrete Pipe Delivery Truck	103
Section (n): Low Loader Truck	107
Record of Implementation	111
My Vehicle Safety Action List	112

Appendices

1. Driving Periods, Breaks and Rest Periods	114
2. Vehicle Controls and Daily Pre-Start Checking	115
3. Vehicle Weights and Dimensions	117
4. Emergency Procedures	122
5. Incident Recording Form	124
6. Sources of Further Information/Useful Websites	131

Foreword

The Health and Safety Authority, with the consent of Mr Dara Calleary TD, Minister of State at the Department of Enterprise, Trade and Innovation, publishes this Code of Practice entitled “Code of Practice for Operators of Quarry Delivery Vehicles (Employing 3 or less)”, in accordance with sections 20(8) and 60 of the Safety, Health and Welfare at Work Act 2005 (No. 10 of 2005).

The aim of the Code of Practice is to improve the level of safety and health compliance of persons operating delivery vehicles to and from quarries, by providing practical guidance as to the observance of the Safety, Health and Welfare at Work Act 2005 (the “2005 Act”), including the provisions of sections 19 and 20 of the Act, and the Safety, Health and Welfare at Work (General Application) Regulations 2007 (S.I. No. 299 of 2007) as amended by the Safety, Health and Welfare at Work (General Application)(Amendment) Regulations 2007 (S.I. No. 732 of 2007). This legislation applies, where appropriate, equally to a self-employed person as to an employer and as if that self-employed person was an employer and his or her own employee, and references in the legislation to an employer should be read as references to a self-employed person as well.

The Code of Practice also provides practical guidance on the observance of specific elements of Road Traffic legislation such as the use of tachographs and provisions on working/driving time, which relate to vital aspects of the safe driving and operation of vehicles.

This Code of Practice comes into operation on November 1st 2012.

Notice of the publication of this Code of Practice was published in the Iris Oifigiúil of Friday 12th October 2012.

Failure to observe any part of this Code will not in itself render a person liable to civil or criminal proceedings. However, where the Code gives practical guidance on observing any of the relevant statutory provisions, compliance or non-compliance with those provisions may be admissible as evidence in criminal proceedings.

Robert Roe
Assistant Chief Executive Officer and Secretary to the Board

Acknowledgements

The Authority would like to thank the following for their contribution to this publication:

Irish Concrete Federation (ICF)

Independent Concrete Control Management Ltd (ICCM)

Eoin Kennedy, ICCM Ltd

Anthony Moran, Cemex

Tony Reville, Kilsaran Concrete Products

Paul O' Mahony, Roadstone Wood Ltd

Michael Delaney, Killeshal Precast Concrete Ltd

Christy Loughnane, Loughnane Concrete (Birr) Ltd

John Maguire, ICCM Ltd

Gerry Farrell, ICF

Michael Joyce, Technical Consultant

Sheena Notley, Health and Safety Authority

Pat Griffin, Health and Safety Authority



Part 1 Code of Practice

1. Introduction

The main work of a quarry products delivery vehicle operator involves driving for work, the safe collection of products from quarries and their subsequent delivery to the customer. This may entail the use of specialised product handling equipment which is carried on delivery vehicles such as cranes, compressors, mixer drums and hydraulic tipping gear. The driver, in addition to being competent in the skills of driving a heavy goods vehicle, must also be trained, and in some cases certified, to operate specific equipment such as forklift trucks and to deliver dangerous goods such as bitumen. Training is a key aspect of ensuring a safe operation and this Code of Practice should become an integral part of driver training.

The overall objective of this Code of Practice, which covers all aspects of the operations of quarry products delivery vehicles, is to provide practical advice and guidance (especially on risk assessment) that will:

- Facilitate safe and efficient operation of vehicles;
- Reduce the risk of incidents involving the operation of quarry products delivery vehicles;
- Provide managers and drivers with the necessary information to comply with best practice.

The Code can be used to understand the types of hazards faced by quarry products delivery vehicle operators and as a reference to other sources of information. In addition, detailed guidance is provided, particularly for the driver, on all aspects of health and safety as it impacts on their work activities.

2. Scope of Code of Practice

This Code of Practice applies to operators of quarry products delivery vehicles (called “transport operators” after this) employing 3 or less employees and is also applicable to transport operators servicing “a quarry” as defined in the Safety, Health and Welfare at Work (Quarries) Regulations 2008 (S.I. No. 28 of 2008). Notwithstanding that definition, the provisions of this Code could also be applied to the operation of quarry products delivery vehicles at an area of a quarry at which any manufacturing process (including the processing of minerals) is carried out, or at any workplace where similar operations are undertaken.

Under health and safety law, transport operators (the vast majority of whom are self-employed) have a legal duty to prepare a Safety Statement. The transport operators Safety Statement must be based on an identification of the hazards and an assessment of the risks, so as to ensure their own safety and health and that of other persons (e.g. other workers at quarries or workers on construction sites).

However, transport operators who are self-employed or employ 3 or less people can opt to implement and comply with this Code of Practice instead of preparing a Safety Statement.

Whether opting to follow this Code of Practice or prepare a Safety Statement, a risk assessment must be carried out relating to all work activities. The act of completing and implementing risk assessments in a comprehensive and effective manner has three main benefits:

- It is likely to reduce the risk of incidents and ill health to workers and the public;
- It will help you to comply with your legal obligations; and
- It may also reduce insurance costs or protect against compensation claims.

It could help to convince a judge that you, as an employer or self-employed person, have taken all reasonably practicable measures to ensure safety and health.

3. How to Use the Code of Practice

The Code of Practice consists of three parts:

Part 1: Provides advice and guidance on topics common to all transport operators such as legislation, driving skills, safe systems of work, emergency planning and so on. There is also a section on specific vehicle and site operations.

Part 2: Sets out risk assessments that will generally be applicable to all transport operators such as maintenance and repair, working alone, health and so on.

Part 3: Sets out risk assessments for specific vehicle types such as tipper trucks, cement mixers and precast delivery vehicles.

There are five steps to using this Code of Practice:

Step 1: Read the guidance material

- Read the general guidance in Part 1.

Step 2: Make a commitment to manage safety and health

- Fill in the Transport Operators details and emergency contact details in Part 2;
- Then make your commitment to manage health and safety and to complete the risk assessments and implement them on an ongoing basis by signing the Form of Undertaking on page 38.

Step 3: Complete the risk assessments

- Complete the generic risk assessments (Part 2, Sections A–F);
- Select and read the vehicle specific guidance and then complete the vehicle specific Risk assessments which are applicable to you (Part 3);
- When you have carefully considered and completed all applicable risk assessments in the document, sign it in the space provided (page 111). Then bring the control measures to the attention of your drivers, who should then also sign the document as a record of implementation (page 111).

Risk assessments identify the key hazards known to cause death, serious injury or ill health to persons affected by transport operations from quarries. Follow these directions for completing Step 3:

A hazard is anything with the potential to cause harm (e.g. vehicles work materials, equipment, work methods / practices, poor work design or exposure to harmful agents such as chemicals, noise or vibration).

- You will be familiar with many of the hazards within the risk assessments listed. An accident or a number of near misses may have occurred with your vehicle in the past. Identify the hazards involved and prevent a re-occurrence;
- Walk around your vehicle and examine all aspects of it from a safety and health point of view. Consider work activities at different times of the day, since the workplace and work systems may change from day to day;
- Consider the work scheduling and work activities on your vehicle. Consider the effect of work overload, rushing, poor equipment, poor maintenance and untidy cabs, all of which are major causes of accidents;
- Ignore trivial issues and concentrate on the significant hazards that could lead to harm;

Where your risk assessments show that control measures are inadequate, you should mark 'x' on the risk assessment document. Then list the missing safety control on the Vehicle Safety Action List (Page 112).

Step 4: Decide on prevention/control measures

- Next identify what action you must take to put the missing safety control in place. When you are devising a safety and health control measure you should implement the principles of prevention by considering them in the following order:

(a) Elimination – If practicable, find a way to remove the hazard completely.

(b) Reduction – If a hazard cannot be eliminated, the next best option is to reduce the danger it poses as far as possible.

(c) Provide information, training and supervision – Ensure that you and every person who is to use any particular vehicle have all the information and skills necessary to secure safety and health. Information can be provided verbally or in writing. Training may be formal or informal. Supervision should be in place until the driver is competent.

(d) Provide and use personal protective equipment (PPE) or clothing – Use PPE as a last resort, after all other ways of eliminating or controlling the hazard have been considered. PPE should be of an appropriate standard and be maintained and stored correctly.

Step 5: Take corrective action and keep a record

- When the corrective action is complete the action list should be dated and signed off. Review your risk assessments at least annually or as work practices change or new vehicles or equipment are added

4. Definitions

In this Code of Practice the following definitions apply:

“ADR”	means the European Agreement on the Transport of Dangerous Goods by Road;
“chock”	means a wedge or similar type of device placed to prevent a vehicle from moving;
“Gross Vehicle Weight”	means the total legally allowed weight of the vehicle when laden (S.I. 771 of 2004);
“HSE”	means the Health and Safety Executive (United Kingdom)
“man lid”	means a device to close an opening on a tank (e.g. opening for top loading of bulk cement and bitumen tankers);
“payload”	means the maximum weight, however comprised, that the vehicle is designed to carry;
“PPE”	means personal protective equipment;
“S.I.”	means Statutory Instrument;
“side creels”	means hinged steel gates fitted on block trucks to provide load security for blocks or other materials;
“tachograph”	means a device fitted to a vehicle/truck or bus for recording vehicle speed, driver hours and vehicle movements;
“tailgate”	means a hinged door on the rear of tipper bodied vehicles;
“ullage”	means unused space available in a tanker;
“vehicle tare weight”	means the weight of the vehicle unladen.

5. Legislation

There are extensive legal requirements placed on transport operators. Almost every aspect of the business from driver training, driver licensing, vehicle weights and dimensions to vehicle maintenance and roadworthiness tests is governed by legislation.

Three main types of legislation apply to transport operators:

- Health and Safety Legislation
- Road Traffic Legislation
- EU Rules on Driving Time



Health and Safety Legislation

Under the main health and safety legislation (the Safety, Health and Welfare at Work Act 2005) employers and self-employed persons have a duty to provide a safe place of work, to provide and maintain safe systems of work and to have adequate emergency plans in place. They must take all reasonable precautions to ensure the safety, health and welfare not only of themselves and their workforce, but also of members of the public and others who might be affected by their work activities.

Under the 2005 Act a vehicle is defined as a workplace: so where specific requirements are laid down for workplaces, such as safe access and egress, these will apply to vehicles, so far as reasonably practicable.

This legislation also requires employees to co-operate with their employer to ensure compliance with health and safety legislation and not to engage in improper conduct or behaviour that is likely to endanger themselves or others.

The Safety, Health and Welfare at Work (General Application) Regulations 2007 set down legal requirements in relation to topics such as manual handling, first aid, personal protective equipment, work at heights, noise, and vibration. Other health and safety legislation such as the carriage of dangerous goods by road, chemicals, and construction legislation may also be applicable to your transport operations.

Road Traffic Legislation

The main requirements of Road Traffic legislation are detailed in the Rules of the Road. Outlined below are some of the specific requirements relevant to heavy goods vehicles.

Mandatory Speed Limits

Vehicles are required to obey the local speed limits and the maximum speed for a heavy goods vehicle of 80 kilometres per hour (KPH). In addition, the law requires that “a vehicle must not be driven at a speed exceeding that which will enable its driver to bring it to a halt within the distance which the driver can see to be clear.”

All heavy goods vehicles should have speed limiters which restrict the maximum speed to 90 KPH. On motorways, vehicles with an 80 KPH speed limit (i.e. HGVs) must not be driven on an outside traffic lane of a carriageway or motorway.

Penalty points

The Road Traffic Act 2002 introduced a schedule of road traffic offences, breaches of which can result in an on the spot fine and having one's driving licence endorsed with penalty points. If a driver decides not to accept the fine, he or she will face prosecution and if convicted may incur additional penalty points. Penalty points remain on the driver's licence for a period of three years. If a driver accumulates 12 or more penalty points, he or she will be automatically disqualified from driving for a period of six months. Further information about offences carrying penalty points may be accessed at the website www.penaltypoints.ie.

EU Rules on Driving Time

Tachographs

Tachographs are covered by the Council Regulation (EC) 561/2006 and European Communities (Road Transport) (Working Conditions and Road Safety) Regulations 2008 (S.I. No. 62 of 2008).

Analogue Tachographs

Drivers must:

- Use the record sheets every day on which they are driving starting from the time they take over the vehicle;
- Ensure that the time recorded on the sheet is correct;
- Enter the following information on each record sheet:
 - Their surname and first name;
 - The date and place where the use of the sheet begins and the date and place where the use of the sheet ends;
 - The registration number of the vehicle;
 - The odometer reading at the start of the first journey and at the end of the last journey recorded on the sheet.
- Operate the mode switch mechanisms so that the following periods of time can be recorded separately:
 - All other periods of work;
 - Periods of availability;
 - Breaks and other daily rest periods.

(Note: Driving time is automatically recorded when the vehicle moves.)

- Be able to produce record sheets for the current day and for the previous 28 calendar days when requested to do so by an authorised inspecting officer as well as their digital tachograph card if they hold one;
- Return the record sheets to the employer for inspection and retention as soon as practicable but in any event not later than 28 days from completing it;
- If the recording mechanism is out of order, mark the record sheet with all the information for the various periods of time which are not recorded correctly by the equipment.

Digital Tachographs

Drivers must:

- Be in possession of a digital tachograph driver's card (issued by the Road Safety Authority) which must be inserted into the digital tachograph immediately when taking over the vehicle;
- Download data from the driver card every 21 days and return the data to his or her employer;
- Return any printouts made in the previous 21 days to the employer for retention.

Details of the driver's hourly regulations are set out in Appendix 1.

Working Time Directive

This is covered by the European Communities (Organisation of Working Time of Persons Performing Mobile Road Transport Activities) Regulations 2005 (S.I. No. 2 of 2005). This legislation sets the working time limits for persons at work including employees and drivers working in quarry delivery activities.

The main provisions are:

- The average working week may not exceed 48 hours;
- The maximum weekly working time must not exceed 60 hours;
- The maximum night work is 10 hours in any 24 hour period;
- A driver is entitled to a break of 30 minutes after 6 hours work and 45 minutes after 9 hours work;
- A period of availability is defined as "any period during which the mobile worker is not required to remain at his or her workstation, but is required to be available to answer any calls to start or resume driving or to carry out other work, including but not limited to periods during which the mobile worker is accompanying a vehicle being transported by a ferry or by a train as well as periods of waiting at frontiers and those due to traffic prohibitions";
- Breaks and periods of availability, which specifically include time spent waiting to load and unload do not count as working time;
- Records of periods of availability must be maintained.



6. Common Hazards

Some of the main causes of death and/or injuries associated with transport activities are:

- People being hit or run over by a vehicle;
- People falling off vehicles;
- Loads falling off vehicles;
- Collapse of a vehicle (usually during vehicle maintenance);
- Overturn of a vehicle;
- Electrocution (usually when vehicles touch overhead power lines);
- Road traffic collisions;
- Slips and trips (usually whilst getting in or out of the vehicle); and
- Musculoskeletal injuries (usually caused by manual handling or poor posture whilst driving).

Not only are there hazards associated with the job of driving but there are also many hazards on sites of which drivers must be aware. Drivers should exercise due care so as not to injure themselves or other site workers. Unfamiliarity with a site can increase these hazards. Listed below are some of the most common hazards associated with sites and driving for work.

Site Hazards

Electricity

Contact with overhead power lines can result in fatal electrocution or breathing/heart failure. This is a particular hazard for tipping vehicles, concrete pumping vehicles, concrete mixer trucks with conveyors and truck mounted cranes.

Drivers should always check for overhead power lines and should as a general rule not work within 6 metres (20 feet) of overhead cables, unless in controlled circumstances, under the guidance of a Site Supervisor.

On large machinery (greater than 5 metres in height) capable of making contact with overhead lines or machinery with attachments that could come close to an overhead line, strong consideration should be given to the fitting of overhead line proximity detection equipment. An assessment on fitting line detection equipment should focus on the prevalence and height of lines where the transport operator will be operating the equipment.

Overhead line detection devices operate on the principle that all alternating current transmission systems in overhead networks generate an electromagnetic field surrounding the transmission line. This electromagnetic field can induce electrical current in a detection device which can, in turn, be used to indicate the presence of the electromagnetic field (and hence the overhead lines) and activate an alarm system to warn of

their presence. This principle is generally used in all devices operated for the purposes of detecting overhead lines in the vicinity of vehicles. This line detection device is usually fitted in the cab of the equipment, with an aerial mounted on the outside.

Suppliers of quarry machinery reaching heights greater than 5 metres either occasionally or continuously should consider offering the option of fitting overhead line proximity detectors on machinery, given that machinery of this nature has the potential to make contact with overhead power lines.

When carrying out a risk assessment on vehicles, consideration should be given to the installation of electrical line detection devices.

Cab Signage

As a reminder to all drivers, the transport operator should fit warning signs on any vehicle or equipment capable of making contact with overhead lines. These signs are available free of charge from ESB Networks (Tel: 1850 372 757) and can be fixed to the appropriate part of the equipment to remind drivers of the risk of approaching overhead lines. They also display the ESB Networks Emergency Contact Number (Tel: 1850 372 999).



Typical Cab stickers (available free from ESB Networks)

Action if Contact is Made

If a vehicle or its attachments come into contact with an overhead line, it could be fatal for anyone who touches the machine. Do not rely on rubber tyres or rubber-soled boots for protection – they will not insulate against a high voltage shock. Tyres can burst into flames and boots can be destroyed. See pictorial presentation below of the precautions that should be taken.



This Figure shows the scenario in the event of hitting an overhead electricity line.

Safe Operation

If the vehicle is not tangled with the overhead line and if it can still be operated, back it carefully away until contact is broken. It may also be possible to lower a tipper or withdraw a high-lift attachment; but you need to take extreme care not to break the line, which may fall onto your vehicle. Do not climb out of the vehicle or attempt to operate the vehicle while standing on the ground outside the vehicle as this may be fatal.

Keep Clear

The driver of a vehicle which comes into contact with overhead lines will usually remain safe in the cab of the vehicle. The driver or people near the vehicle (or equipment) are at risk if they make simultaneous contact with the vehicle and earth. Do not touch the vehicle or anything attached to it.

Get Help

You, or someone else, should contact ESB Networks emergency number (1850 372 999), tell them your exact location and ask them to disconnect the power immediately. If you have a mobile phone or CB radio, use that. You should have ESB Networks emergency telephone number on a warning sticker in the cab or preferably in your mobile phone.

Jump Well Clear!

If you have to leave the cab, jump well clear so that no simultaneous contact is made between you, the vehicle and the ground. Land on your feet and do not touch the ground with your hands. Move away at once using short steps, or bunny hop with both feet together. Remember that the line may still be live or it may automatically be switched on again at any time and you may still be close enough to be electrocuted.

Stay Clear

Do not go back to the vehicle even if you think it is safe to do so. It may still be live. Nobody should approach the vehicle until ESB Networks has confirmed that it is safe to do so.

Further guidance is provided in the ESB Networks *Code of Practice for Avoiding Danger from Overhead Electricity Lines 2008*.

Unstable/Uneven Ground

Vehicles can overturn if driven or operated on unstable ground with the consequent risk of serious or fatal injury. Drivers should visually check the ground conditions and if in doubt contact the Site Manager or their Company Supervisor. Drivers should be aware of the limitations of their vehicles and the risk of overturning. Special care should be taken during tipping or moving on wet or steep roads, and when operating near pedestrians or excavations.



Slips, Trips and Falls

The ground at quarries and building sites is often uneven and may present a hazard to a driver working there. Always check for uneven surfaces before stepping down from the vehicle. Also note that slips and trips are often contributory factors in falls from vehicles.

Falls from Vehicles

The majority of falls from vehicles occur when people are getting in and out of the vehicle or working at height on the vehicle. Avoid the need to work at height where possible. If unavoidable provide on-vehicle fall protection systems, on-site systems such as cat-walks, collective protective fall measures such as soft landing systems or personal restraint or fall arrest systems, whichever is most appropriate. Always keep at least three points of contact with your hands and feet when climbing in and out of the vehicle. Never jump down from the vehicle. Ensure that steps and footwear are in good condition and clean.

Vehicle Collision

Every year there are many accidents where workers on sites are injured or killed as a result of being struck by a vehicle. Drivers should observe speed limits and traffic routes on sites. They should watch out for other workers on sites and should also take care of their own safety in regard to other site traffic. Drivers should position their vehicle on site so as not to cause a hazard.

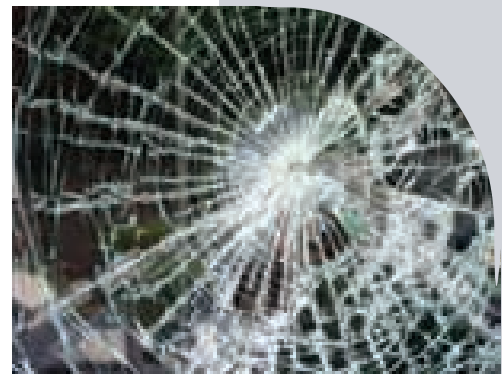

Product Safety

Wet cement coming in contact with exposed feet and hands can be a skin irritant and the chromate in cement can be a sensitizer. Both can result in dermatitis. Drivers should read the relevant safety data sheets and be aware of any hazards associated with the product they are transporting. The data sheets provide specific information on protective clothing and first aid.

Manual Handling

As the majority of product is handled by mechanical handling equipment the risk of a manual handling injury is reduced. However, care should be taken when carrying out any manual handling activities and mechanical aids such as pallet trucks, tail-lifts, cranes, etc should be used where possible to reduce manual handling.

Noise

Noise is damaging to your hearing. As a general rule, if you have to shout to be heard by a person who is only a metre away then noise levels are too loud and ear protection should be worn.

Vulnerable Workers

Young workers or helpers and non-Irish national workers may be particularly vulnerable to hazards on site and on the road. Good communication is essential. All new employees should be given Induction Safety Training, be advised on the content of the Code Of Practice and be supervised at all times during their training

until competent to work alone. Safety related issues such as escape routes, emergency drills, radio procedures and fire fighting should be clearly explained and all emergency procedures practised to ensure that they are understood.

Driving For Work Hazards

Inappropriate or Unsafe Use of the Vehicle

If a vehicle is not suitable for the task or the load being carried, this can affect the vehicle safety. Unsecured loads can result in loss of vehicle control or product falling off and hitting people, causing road obstructions, traffic disruptions and road traffic collisions, especially as drivers swerve to avoid fallen items. Overloaded vehicles can also cause excessive road and pavement damage and can impact on vehicle stability and safety.

Driver Error

Human error is the cause of most road collisions. The risk from driving hazards is increased greatly by increasing the time that the driver is working whether over extended periods or over long distances.

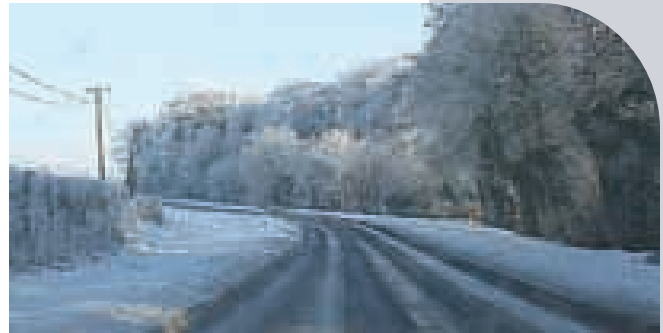

Driver Distraction

Driving is a complicated task and requires continuous concentration. Anything that distracts a driver's attention can increase the likelihood of an incident occurring. Distractions can be internal (talking to passengers, drinking or eating, reaching for objects, loose objects, using phones or other electronic devices) or external (looking at road signs or scenery). Risks can be reduced by not eating or drinking whilst driving, presetting controls, securing loose objects and pulling over to adjust equipment or take calls.

Adverse Weather Conditions or Poor Roads

Adverse weather or poor roads can increase risks. Risks can be reduced by using alternative routes and rescheduling trips to times of less extreme conditions. For further information on driving in adverse weather see weather alerts at www.rsa.ie the Road Safety Authority's Severe Weather Advice for Road Users.

Fatigue

Drivers fatigue contributes to one in five road deaths in Ireland. Inadequate rest (both before and during a trip), long hours, night driving, loading and unloading vehicles, afternoon driving, having to rest away from home, truck vibration and uncomfortable cab conditions can all cause driver fatigue. Fatigue can result in loss of concentration or worse the driver falling asleep at the wheel. EU Rules regulate driver's hours with respect to the average working time and the amount of rest that must be taken daily and weekly.

Speeding

Speeding or driving too fast for road conditions is a major cause of road traffic collisions. Speed limits set the maximum speed for the road, but there are many circumstances when it is not safe to drive at that speed, such as in adverse weather conditions or in heavy traffic. Drivers who travel at higher speeds have less time to identify and react to what is happening around them, take longer to stop and are involved in more severe collisions. Speeding also aggravates other issues such as fatigue.

Drugs and Alcohol

As a driver of a heavy good vehicle on the public road, it is mandatory that you should not be under the influence of drugs or alcohol as required by Section 13 of the Safety, Health and Welfare at Work Act 2005. Drivers should be aware that certain over the counter medications may also affect driving ability.



Drivers should be aware that under the Road Traffic Act 2006 Gardaí have the power to carry out “Mandatory Breath Testing”. Drivers who are stopped at a checkpoint or involved in a collision are required to provide a breath sample and if their blood alcohol levels exceed the legal limit they face disqualification from driving.

Lone Working

As drivers usually work by themselves without close or direct supervision they are classified as “lone workers”. Lone workers should be capable of responding to emergencies and a communication system should be put in place to ensure safety.

Health and Ergonomics

Driving a heavy vehicle can be demanding work and can involve prolonged sitting often resulting in the driver adopting tiring or painful positions which can contribute to lower back pain. Drivers should take regular breaks and ensure that seat positions are correctly adjusted. In addition drivers should try to exercise regularly and eat a well-balanced diet. Also try to relieve any stress or emotional upset as these can also affect your driving.

Poorly Maintained Vehicles/Vehicle Maintenance

Vehicles should be appropriately maintained and roadworthy. The maintenance of the product handling equipment requires special expertise. In particular, there are safety rules to be observed:

- Ensure that a raised tipper body is adequately propped before carrying out any work under it. The prop used should be designed to carry the weight and locked or secured in position;

- Ensure mixer drums are locked to prevent rotation and keys are removed from the ignition;
- Entry into bulk tankers or mixer drums requires special precautions as outlined in the Health and Safety Authority *Code of Practice for Working in Confined Spaces*. More information on vehicle maintenance is available in the Road Safety Authority's Guide for Keeping Your Commercial Vehicle Roadworthy at www.rsa.ie.



(Source – HSG 144 Health and Safety in Construction HSE).

Fire

Vehicle fires may occasionally occur and drivers should be able to respond to such emergencies.

The key elements to any safe transport operation are:

- The Driver
- The Vehicle
- The Journey and
- Safe Systems of Work

The following sections provide advice, clear criteria and standards in relation to the management of these key elements.

7. The Driver

Training

The skill and competence of the driver is critical to safety in all transport operations. As the vehicle used for the transportation of concrete products usually carries the equipment for offloading the product (e.g. a crane or tipper body), the driver should have received appropriate training and certification (if required) in the operation of the vehicle and any additional equipment.

Documents

Driver's Licence

Drivers should be in possession of the appropriate driving licence for the vehicle they are using. Drivers should carry the licence with them at all times. Drivers who have their licences endorsed or who accumulate penalty points under the Road Traffic Act 2002 should inform their Transport Manager or Supervisor and client company.

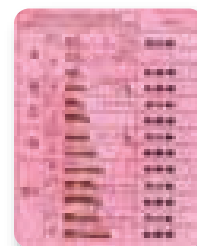

Safe Pass

Drivers making deliveries to construction sites must be in possession of a current "Safe Pass" Registration Card as required by the Safety, Health and Welfare at Work (Construction) Regulations 2006 (S.I. No. 504 of 2006).



Certificate of Professional Competence (CPC)

The Road Safety Authority implemented the Driver CPC requirement for trucks from 10 September 2009. From that date all new truck drivers must pass a theory test and a practical test, as well as the current driving test, in order to obtain the Driver CPC Qualification Card. This card is required in addition to the driving licence.



If you have a full truck licence on or before 10 September 2009, you will not be required to sit the extra tests. However, you will have to do one day of training per year over the following five years to ensure you retain

your Driver CPC. The licence you have at present identifies that you have a truck licence and this is evidence that you have a valid Driver CPC. On completion of your five years of training you will then be issued with a Driver CPC Qualification Card.



Operator Licence

If the vehicle is owned and operated for “hire and reward”, then the owner must be in possession of a road haulage operator’s licence and each individual vehicle must display the appropriate disk (Road Transport Act 1999, Part 6).

Medical

Drivers should ensure as far as reasonably practicable that they are medically fit at all times to perform their duties.

Legal Compliance

Drivers should familiarise themselves with the Rules of the Road (see www.rulesoftheroad.ie) and ensure that they are fully knowledgeable of all relevant aspects. A copy of the revised Rules of the Road should be carried in every vehicle.



Driving Standards

The driver is the representative of the industry and the individual company on the road, and his or her behaviour is therefore very important. While observance of the law is the first duty, safe and courteous driving displays an understanding of the needs of other road users.

The following guidelines should be observed:

- Avoid unnecessary use of the horn;
- Allow adequate space for other road users;
- Do not drive too close to the vehicle in front;
- Do not pull out onto a road if it causes other road users to brake excessively;
- Follow all site safety rules and traffic management systems (e.g. speed limits, one-way systems, traffic lights, etc);

- Watch out for pedestrians, particularly young children or elderly persons, crossing when traffic is stopped (use your fish eye mirror before moving off);
- Watch out for cyclists when making left turns. Continuously check your mirrors and stop if you have lost sight of a cyclist;
- Avoid reversing manoeuvres where possible. If unavoidable ensure that the area behind you is clear. Use your reversing camera (if fitted). If you cannot see, get out and check. As a last resort get a competent person to assist you and ensure that they remain in your vision;
- Do not increase your engine speed as the lights are about to change;
- Maintain good lane discipline and a safe distance from other traffic;
- Position yourself in the correct lane when approaching a junction or roundabout; and
- Be prepared to make allowances for the behaviour of other road users and be willing to give way (even if you are in the right), if it means avoiding a collision.

Personal Safety

Drivers must ensure that:

- A safety belt, more commonly referred to as a seat belt, (when fitted in the vehicle) is worn at all times (this is a legal requirement under the European Communities (Compulsory Use of Safety Belts and Child Restraint Systems in Motor Vehicles) Regulations 2006 (S.I. No. 240 of 2006));
- The cab is kept in a clean and tidy condition as loose equipment can be a hazard and can lead to accidents (e.g. cans or rags getting under brake or clutch pedals).
- They wear a High Visibility jacket or vest if they have to leave the vehicle, including in the event of a breakdown;
- Handheld phones or other handheld communication equipment are not used while driving. This is an offence and drivers using handheld phones may incur two penalty points on their licence. The definition of "holding a mobile phone" covers holding it by hand or supporting it with some other part of the body. The definition prohibits the practice of cradling a mobile phone in the nook of the neck and shoulder (Road Traffic Act 2006).

Guidelines on the use of mobile phones are also available on the Road Safety Authority website (www.rsa.ie).

Complaints

Companies should have a procedure for dealing with complaints. All complaints should be recorded and investigated, and where necessary appropriate action taken.

8. The Vehicle

Ensure that the vehicle is suitable for the task, for the load being carried and the workplace it will be operating in. The vehicle should also be well maintained and roadworthy.

Vehicle Specification

Vehicles should be specified to ensure that they are capable of operating to the maximum gross vehicle weight. As most vehicles in the industry are fitted with product handling equipment, the buyer should ensure that the product handling equipment is compatible with the vehicle, does not cause instability and is mounted so as to ensure that axle weights are not exceeded when the vehicle is fully loaded. In particular, the operator should ensure that the tyres are correctly rated for the wheel loads.

The safety aspects of the operation of product handling equipment must also be taken into account and any necessary training undertaken.



Vision

As a minimum, vehicles should be fitted with mirrors to provide the maximum all round vision, including kerb side and front (fish eye or Cyclops) mirrors. Wide angle and close proximity mirrors should be provided. When fitting reversing alarms the wideband low frequency type is recommended as they minimise nuisance noise emissions. The installation of reversing cameras is best practice and is strongly recommended to deal with vehicle-driver blind spots.

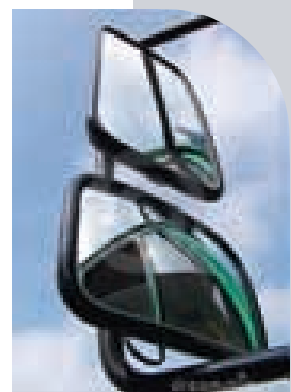

Pre-Start Vehicle Check

Before the start of each shift, a driver should carry out a vehicle check to ensure the vehicle is in a roadworthy condition.

Use your approach to the vehicle as part of an overall visual inspection:

- Check that the whole unit sits straight and level;
- Note any excessive steering lock applied;
- Check for any signs of damage including broken lights/reflectors; and
- Check for leaks beneath the vehicle.



Then carry out the following external checks:

- Engine oil level (top up as required);
- Coolant level in the header tank (top up as required);
- Windscreen washer level (fill up as necessary);
- Fuel level in the diesel tank (fill up as required remaining beside the vehicle while filling);
- Windows, mirrors, lights, number plates and vehicle markings are clean and functional.

Note: as vehicles are operating on building sites, it is mandatory for drivers to ensure that these vital parts of their vehicle are kept clean at all times;

- Wheels, wheel nuts and tyres;
- If the vehicle is an artic, check air and electrical connections to the trailer and that the trailer is securely coupled to the tractor; and
- Check handholds and steps to the cab and ensure that they are clean and secure before use.



Enter the vehicle, start the engine and check:

- Operation of lights, wipers, horn;
- Build up of air pressure;
- If any warning lights are flashing; and
- Mirror adjustment.

The driver should ensure that any product handling equipment is in good working order, that there are no air or oil leaks or other malfunctions. (See Appendix 2, Example of Daily Pre-Start Checklist).

Finally, insert a new tachograph chart or driver card, whichever is appropriate.

More information on vehicle checks can be found in vehicle handbooks and is also available in the Road Safety Authority's *Guide For Keeping Your Commercial Vehicle Roadworthy* at www.rsa.ie.

Vehicle Maintenance

The law requires that every vehicle and trailer, and all parts and equipment of every vehicle and trailer, be maintained in good and efficient working order, and be maintained so that no danger is liable to be caused (Road Traffic (Construction, Equipment and Use of Vehicles) Regulations 1963 (S.I. No. 190 of 1963)).

While it is the responsibility of the operator to arrange and schedule maintenance, the onus is on the driver to report vehicle defects. This should be carried out either verbally or, preferably, in writing using a defect reporting system.

Both the driver and the owner can be found guilty of an offence, if a defective vehicle which is a danger to the public is driven in public.

Vehicles and the product handling equipment should be maintained in accordance with the manufacturer's instructions and records maintained.

Statutory Inspections

Vehicles are subject to the following statutory inspections:

Test/Inspection	Inspection Frequency
Roadworthiness Test	Annually
Analogue Tachograph	Every 2 years
Calibration	Every 6 years
Digital Calibration	Every 2 years
Crane Inspection	Every 12 months
Bitumen Tankers	Annual ADR inspection and pressure tests every 3 years
Forklifts	Every 12 months
Cement Tankers	Best practice requires the Pressure Relief Valve and Tank Pressure Gauge be tested and certified every year. Tanker inspection interval to be determined by a competent person ref: regulation 30 of the Safety, Health and Welfare at Work (General Application) Regulations, 2007 (S.I. no. 299 of 2007).

Load Security

Load security in transit is critical. This should be incorporated in the vehicle specification, including items such as side creels for block trucks, headboards, anchorage points and other dedicated load-securing mechanisms. All products should be retained and restrained within the vehicle during transit. Ensure that the load is well secured and that material such as sand, blocks or concrete are not likely to discharge onto the road or drop onto another vehicle or person. All anchor points and restraints should be regularly inspected for damage or deterioration and load security checked regularly during the journey.



When the vehicle has been offloaded ensure that there are no concrete fragments remaining on the load deck which could fall off and cause damage to other vehicles or people (e.g. breaking a windscreen). Also ensure that tailgates are secured following discharge prior to travelling on public roads.

Further details on load security are available in:

- European best practice guidelines on cargo securing for road transport. European Commission Directorate General for Energy and Transport
http://ec.europa.eu/transport/road_safety/vehicles/doc/cargo_securing_guidelines_en.pdf
- Code of Practice: Safety of Loads on Vehicles, Department of Transport (UK)
www.dft.gov.uk/pgr/roads/vehicles/vssafety/safetyloadsonvehicles.pdf

Tare Weight

Vehicles should be specified to have the lightest tare weight, so that the payload can be maximised thereby reducing the number of journeys. There are a number of factors to be considered which will reduce tare weight (subject to the vehicle manufacturer's approval and compliance with the relevant vehicle construction and use regulations):

- Smaller fuel tank;
- High tensile steel (tippers);
- Smaller water tank (mixer truck); and
- Plastic chutes (mixer truck).

Vehicle Weights

The maximum weights allowed by the vehicle manufacturer must be followed. Details of the maximum legal gross vehicle weight for the most commonly used legal maximum gross vehicle combinations in the industry are given in Appendix 3. A summary of these maximum legal gross weights is as follows:

Two Axle Rigid	18 tonnes
Three Axle Rigid	26 tonnes
Four Axle Rigid	32 tonnes
Five Axle Articulated Combination	42 tonnes
Six Axle Articulated Combination	44 tonnes

Rigid and trailer Combinations

Three Axle Rigid and Three Axle Trailer	44 tonnes
Four Axle Rigid and Three Axle Trailer	44 tonnes
Four Axle Rigid and Two Axle Trailer	42 tonnes

Notes:

- These are maximum weights and there are several conditions which must be met for a vehicle to operate at this weight;
- The maximum weights for the three and four axle rigids are subject to the condition that the weight of either of the drive axles does not exceed 9.5 tonnes (Road Traffic (Construction and Use of Vehicles) Regulations 2003 (S.I. No. 5 of 2003));
- The maximum gross vehicle weight of five axle articulated combination consisting of a two axle tractor and three axle trailer to revert to 40 tonnes. As per S.I. 576 of 2009 Road Traffic (Weight Laden of 5 Axle Articulated Vehicles) Regulations 2009.

Overloading

Vehicles must not be loaded above the maximum weights shown above. Overloading of vehicles must be avoided for many reasons:

- It may impact on vehicle stability and safety;
- It causes excessive road and pavement damage;
- It is in breach of Road Traffic law and both consignor and operator may be subject to heavy fines; and
- It may result in shedding of loads or part of loads and put third parties at risk.

In addition to ensuring that the vehicle does not exceed the maximum gross vehicle weight, companies should check that the load is evenly distributed to prevent overloading of individual axles.

Companies should monitor tare weights to ensure that there is no accumulation of product inside mixer drums or bulk tanks, which can give rise to overloading.

Exceeding Vehicle Dimensions

Drivers must ensure that loads do not hang over the edge of the vehicle. They should also ensure when carrying high loads that there is no risk of striking overhead lines or a low bridge during their journey.

Vehicle Image

Heavy goods vehicles can be intimidating to many road users so a professional driver will make every effort to minimise the impact. Drivers must ensure that vehicles are kept as clean as possible. A clean vehicle is more pleasing to the eye and much less intimidating. It will also enhance the company image and reassure the public that it is well maintained.



9. The Journey

Planning the Journey

When planning the journey take account of the following factors:

Routes

Use safe, suitable routes taking account of possible restrictions or hazards such as bridges, tunnels, overhead restriction and level crossings;

Scheduling

Ensure that schedules are realistic. Allow time for proper rest breaks and recovery time for drivers (see Section 5). Take account of possible delays (e.g. during peak traffic flows).
Make allowances for trainees or new drivers;

Distance

Check if long-distance journeys can be reduced or avoided by changing schedules. If unavoidable, ensure appropriate rest breaks are taken;

Weather conditions

Take account of any predicted bad weather and ensure that vehicles and drivers are properly equipped to deal with such weather conditions. Change schedules or routes if necessary.

Road Safety

Because of the size and weight of the vehicle, the consequences of an incident involving a car, pedestrian, pedal or motor cyclist are likely to have serious or even fatal consequences for the other road users. The driver therefore needs to be extra vigilant to prevent accidents.

Driving Conditions

At times bad weather and poor visibility will determine driving conditions. Fog, snow, ice and heavy rain reduce your ability to control the vehicle. Bright sunlight can reduce your ability to see and hot weather can affect the road surface. Drivers should adjust their driving to suit the conditions: particularly by reducing speed and increasing the distance between their vehicle and the vehicle in front.

The Tachograph

The tachograph must function properly and be used to record driving times, breaks and rest periods. The driver should ensure that he/she has inserted a chart in the tachograph head and has filled in the necessary

detail. If the vehicle is fitted with a digital tachograph, the driver should be in possession of a digital tachograph card issued by the Road Safety Authority. This card should be inserted in the digital tachograph. Compliance with tachograph regulations is covered in Section 5, Legislation;

The Road Safety Authority can be contacted about rules relating to driver's hours and tachographs.

Traffic Conditions

Traffic conditions can vary from hour to hour, day to day, week to week and from town to town. Drivers must be aware of this and adjust their driving and attitude to suit changing conditions. The irritations of traffic and the bad behaviour of other drivers on the road must be accepted as part of the normal driving job.

Children in Vehicles

Children and/or pets should not be carried in the cab of a quarry products delivery vehicle while at work.

10. Safe Systems of Work

Most of the operations covered in this section involve deliveries to construction sites. Outlined below are general safe systems of work. For safe systems of work for specific vehicle and site operations see Part 3.

General Site Rules

On arrival a driver should note and observe the site rules in relation to safety equipment, speed limits and other relevant issues. Always follow the traffic management system that is in place.

Traffic Management

Vehicles should not be parked so as to present a hazard to other persons on a site.



Drivers must comply with the traffic management system in place, especially when queuing to offload on the public road. Where it is necessary to discharge a load while parked on the public road suitable precautions should be taken with the use of cones or tape to alert other vehicles to your presence.

Personal Protection Equipment (PPE)

All personal protection equipment should be CE marked. Drivers must wear the basic safety equipment at all times on site: High Visibility vest, safety footwear and helmet. Additional safety equipment such as ear or eye protection may be required on some sites. Always keep your High Visibility jacket or vest close to hand: for example, in the vehicle cab, so that you can wear it when exiting the vehicle.



General Loading and Offloading Rules

Loading and unloading should be carried out in areas away from pedestrians and vehicular traffic. The area should be, as far as possible, in good condition, even, flat, free of pot holes and well lit. Vehicles should be properly braked and stabilised during loading and unloading operations so that no unsafe movements can occur. Loading and unloading operations should be stopped immediately if an unauthorised person enters the work area. Do not load or unload in the vicinity of overhead power cables (see Section 6) and where possible, load and unload the vehicle without anyone on the back of the vehicle. Do not unload anywhere that you consider to be unsafe; report any concerns back to the Site Manager or your Company Supervisor.

Fuel and Oil Usage

High environmental standards should be adhered to at fuel and oil storage locations.

Fuels and Oils

When filling the vehicle with diesel, the driver should ensure that:

- It is not overfilled;
- There is no spillage of diesel;
- The dispensing nozzle is replaced securely;
- The cap on the diesel tank is fitted tightly so that there are no spillages on the road; and
- He/she stands by the vehicle at all times during fuelling.

Likewise when topping up engine oil, care should be taken not to overfill and to replace fill caps securely.

Drivers or persons involved in any cleaning of spills should refer to the safety data sheets for the fuels and lubricants provided by the supplier.



Leaks

Drivers should report all fuel and oils leaks to their Transport Manager or Supervisor immediately and have them repaired. All spills must be cleaned up immediately with suitable material which is disposed of correctly, in compliance with relevant regulations.

Fuel Storage

Fuel tanks should be enclosed in a bund with a capacity of 110% of the tank or if there is more than one tank 25% of the total. The bund should be impervious without any drain. The bund should be plastered internally and externally. It should be cleaned out on a regular basis.

Fuel tanks should be clearly labelled giving details of their contents and associated hazards. To avoid spillage during filling, each tank should be clearly marked with a tag showing fuel grade (even if only one grade is kept) and tank capacity.

The fill pipe should have a gate valve and a non-return valve, and if not, inside the bund should have a drip tray. If the fill pipe is remote from the tank and the tanker driver cannot see the tank from the fill point, the fill pipe should have a high level cut off, which will prevent the tank from overfilling.

The tank should have a vent pipe with the top turned 180° to prevent ingress of water. The vent should be located as near as possible to the fill pipe to alert the driver in the event of an overfill.

The tank should have a gauge located near the fill point and should have a high level alarm.

The fuel dispensing pumps should be located within the bund area or in an adjoining bunded/secure area. Special protection is required for the fuel feed-line from the storage tank to the pump if it is not within the bund.

The fuel dispensing and tanker offloading area should be concreted and drain into a fuel class interceptor which will prevent the escape of any fuel spills into the drains.

Drivers should be encouraged and trained to deliver maximum fuel efficiency. Fuel consumption should be monitored and action taken for continuous improvement.

General Transport

Vehicle traffic in and out of operations and through minor or congested roads can be disturbing to the local community. Routing of vehicles should be carried out to minimise disturbance in an environmentally sensitive way and in compliance with any relevant planning requirements.

The following measures should be taken to minimise the impact of traffic on the local environment:

- Vehicle cleanliness: vehicles should be washed regularly;
- Road cleanliness: companies should ensure that vehicles leaving their operations are effectively cleaned, by an appropriate means including wheel-washing facilities, if necessary, to prevent the spread of dust and aggregate onto the public highways;
- Sheeting and load security: companies should ensure where appropriate that loads of finer materials leaving operations are properly loaded, trimmed and sheeted to prevent dust ($\leq 5\text{mm}$) or any part of the load causing a hazard to the public. Alternatively the spraying of loads can be used to dampen dust and reduce dust blows from an open truck;
- Vehicle parking: companies should provide on-site parking where possible;
- Vehicle maintenance: all vehicles should be well maintained and regularly serviced to ensure safety and minimise exhaust emissions and other environmental hazards such as excessive noise and leaks;
- Vehicle emissions: vehicles should be specified to the latest EU standards (Euro 5);
- Vehicle exhausts: vehicle exhausts should be designed to minimise the generation of dust.

Waste oil and other waste materials such as batteries, tyres and filters arising from vehicle maintenance should be recycled. There are several specialist licensed companies providing this service. Companies should ensure that waste collection operators have the appropriate permits and licences. Waste oil tanks should be bunded. Spill kits should be provided in garages and areas where oils are stored and handled. Oil and fuel leaks which occur as a result of breakdowns or accidents or component failure should be cleaned up and any material such as oily rags disposed of in compliance with the Hazardous Waste Regulations.

Sheeting

Where sheeting is required, it should be automated or fitted on the vehicle so that the load can be sheeted and unsheeted easily by the driver at ground level or from a suitable gantry.

Emergency Procedures

Under health and safety law, it is a legal requirement for employers to have adequate plans and procedures in case of an emergency or serious and imminent danger.

Appendix 4 outlines emergency procedures in the event of a vehicle breakdown or fire.

Drivers must report all incidents (near misses, accidents, road traffic collisions, product spillages, etc) immediately to their Transport Manager or Supervisor. As soon as possible or on return to the depot, drivers should complete an incident recording form (Appendix 5). In addition:

- Provide a means of recording such events in all vehicles (eg. incident report form, camera);
- Maintain proper records of incidents and comply with statutory reporting of accidents to the Health and Safety Authority;
- Investigate all relevant incidents and identify and implement necessary corrective or preventive actions;
- Ensure all employees and management co-operate in the investigation of such events, including investigations undertaken by the Health and Safety Authority and/or An Garda Síochána.

Road Traffic Collisions

In the event of a road traffic collision, drivers are required to provide their name and address, the name and address of the owner of the vehicle, vehicle registration and details of motor insurance to the Gardaí and the other party.

Where possible, photograph the scene. The photographs should record all the relevant detail such as damage to vehicles, position on the road, any relevant signage and any other relevant information. In addition, drivers should take notes of the details of the accident in order to enable completion of the incident reporting form (Appendix 5).



Sheeting from ground level

Product Spillages

Drivers should take all reasonable care to prevent spillages, particularly on bends, roundabouts, junctions, steep hills and slip roads. Should any spillage occur, drivers should report this immediately. The relevant company must respond promptly and take the necessary remedial action.

Reporting of Accidents

Following an accident at work where the driver is out of work or unable to carry out his or her normal work activities for more than three days the driver of the vehicle or his or her employer must report the accident without undue delay to the Health and Safety Authority. An accident report can be made on line at www.hsa.ie or a form (IR1 form) can be requested from the Health and Safety Authority at Tel: 1890 289 389.

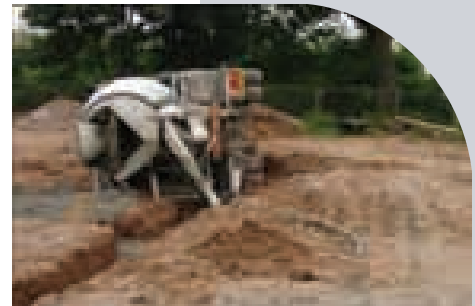



Part 2

Risk Assessment Document for Transport Operators with 3 or less Employees

Transport Operator's Details

Owner's Name:

.....

Telephone:

.....

Owner's Address:

.....

.....

.....

.....

List Your Vehicles Registered Number	Vehicle Type	Overall Length
.....
.....
.....
.....
.....
.....
.....
.....
.....
.....
.....
.....

Form of Undertaking

Completing and implementing the findings of this Quarry Products Delivery Vehicle Risk Assessment document will help you to meet your duties under Section 20(8) of the Safety, Health and Welfare at Work Act 2005.

Code of Practice – Risk Assessment

This is my programme in writing for managing health and safety. It is aimed at protecting myself and others from the risk of accidents and ill health in the course of my work activities.

I undertake to:

- Provide a safe place of work;
- Provide safe plant and machinery;
- Provide information, training and supervision necessary to control risk;
- Use safe systems of work;
- Advise all who work with or close to my quarry products delivery vehicle of the hazards identified in this risk assessment and the controls put in place to protect them from injury;
- Suspend work if a dangerous situation arises which is not an emergency, until the hazard is controlled;
- Provide and ensure proper use of personal protective equipment (PPE);
- Provide equipment and fittings as required by road safety legislation;
- Review health and safety on my vehicles and this document at least annually.

Signed:

Print Name

Date:

Emergency Telephone Numbers

Contacts	Numbers
Emergency Services	
Next of Kin	
Own Doctor	
Quarry Manager	
Garda Station	
Health and Safety Authority	1890 289 389
ESB Networks	1850 372 999
Breakdown Assistance	

Section A: General Requirements

List All Trucks Used			
Vehicle Registration Number			
I will ensure that:			
Drivers hold the appropriate valid licence for the vehicle they are driving.			
Driving licences of all drivers are inspected, verified annually and copies are retained on file.			
Vehicles are used for intended purposes only.			
All drivers demonstrate an understanding of the Rules of the Road and traffic regulations, including ability to read and understand road signage, signals and emergency signalling/signage.			
Drivers will observe the Rules of the Road and comply with traffic regulations including speed limits, access to restricted areas and parking.			
Drivers will not consume food or drink while the vehicle is in motion and will not refer to or review any reading material, including delivery dockets etc while the vehicle is in motion.			
Drivers will advise the company of any imposition of penalty points, licence endorsement or disqualification.			
All road traffic collisions are promptly reported to Supervisors/ Management immediately and An Garda Síochána if necessary. Drivers will co-operate fully with all subsequent investigations.			
On-site traffic management and safety rules are followed.			

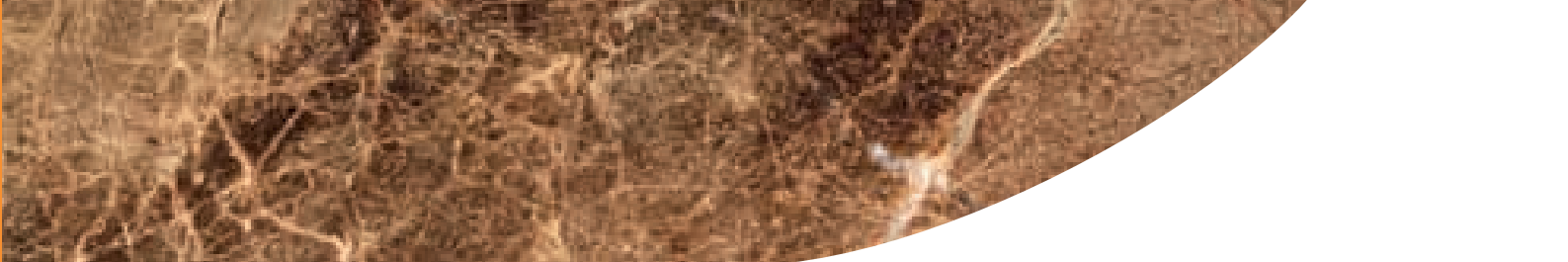

List All Trucks Used

I will ensure that:

Unauthorised personnel will not be carried as passengers or allowed access to any part of a vehicle. Children and pets will not be carried in or on the vehicle while at work.

A safety belt when fitted in the vehicle is worn at all times.

The cab is kept in a clean and tidy condition to prevent accidents.

A first-aid box and manual is maintained in the vehicle at all times.

A handheld phone or other handheld communication equipment will not be used while driving. Calls using hands free equipment are kept to a minimum.

Smoking in the cabs of all vehicles is prohibited.

Warning signs concerning the prohibition of smoking, the carriage of passengers, children or pets and the illegal use of mobile phones and the dangers from overhead power lines are placed in the cabs of all vehicles.

Employees will not interfere with the operation of any safety device including speed limiters (where fitted), alarms, beacons, lights or tachograph controls.

Drivers will comply with the provisions of the Working Time Act and tachograph regulations in relation to maximum working times, which will not be exceeded. Mandatory rest breaks in accordance with the above legislation are observed.

Drivers are issued with standard protective clothing which includes: safety footwear, gloves, hearing protectors, eye protection, High Visibility vest or jacket and helmet. Drivers will use such PPE and obtain replacements for damaged, worn or lost items.

List All Trucks Used

I will ensure that:			
Employees operating company vehicles take account of prevailing weather and site conditions and take appropriate actions, which include reduction of speed, alteration of delivery schedules and other arrangements as may be necessary to ensure the safety of themselves, the general public and people employed on sites.			
Employees are instructed to report vehicle or trailer defects and not to operate defective vehicles. The means for such reporting are explained to and understood by all employees.			
In the event that a load shifts during transit, the driver will park the vehicle safely and take appropriate corrective action, which may include assistance from base.			
Employees will obtain direction from management in relation to the above as and when necessary.			
Additional Controls			

Note: If a safety control measure is missing, indicate that on Your Action List on pages 112 and 113.

Section B: Servicing, Maintenance and Repair

List All Trucks Used

Vehicle Registration Number			
I will ensure that:			
All vehicles including trailers and attachments are serviced and maintained in accordance with manufacturer's recommended service and maintenance schedules appropriate to the use of the vehicle.			
All maintenance is carried out by a competent person.			
Vehicles will not be operated with any defects which either contravene the Road Traffic Acts or which represent unsafe work practice.			
Records of servicing, repairs and maintenance to all vehicles, trailers, attachments and tachographs are maintained and available for inspection when required.			
A raised tipper body is adequately propped before carrying out any work under it.			
Tractor cabs on articulated vehicles are properly secured when lifted for maintenance or repair purposes.			
All defects are reported immediately and remedial action taken.			
Additional Controls			

Note: If a safety control measure is missing, indicate that on Your Action List on pages 112 and 113.

Section C: Working Alone and Communication

List All Trucks Used

Vehicle Registration Number			
I will ensure that:			
The risks are minimised or can be controlled by one person.			
Any lifting/moving can be done safely by one person.			
Access and egress is suitable for one person.			
The person is medically fit to work alone.			
The person is trained/competent to work alone.			
First aid is provided for the lone worker.			
Communication is provided for the lone worker (e.g. radio/mobile phone).			
Supervision/spot checks are carried out to ensure safety of lone workers.			
Safety Practices			
Lone workers are fully trained to carry out the task on their own.			
Lone workers are trained and fully aware of all safety control measures.			
The following tasks are not suitable for lone workers			
Confined space work (e.g. entry into drum mixer bottles).			
Working on live electrical equipment.			
Use of ladders which cannot be secured.			
Working on or over deep water.			
Working on any machine where isolation is not possible.			
Additional Controls			

Note: If a safety control measure is missing, indicate that on Your Action List on pages 112 and 113.

Section D: Slips, Trips and Falls

List All Trucks Used

Vehicle Registration Number			
I will ensure that:			
Cabs and workplaces are kept neat and tidy.			
Cables/hoses are not trailed across walkways.			
Handrails/guardrails are provided where necessary.			
Access ladders and steps are in good condition, clean and secure.			
Edge protection is provided at height .			
Any oil/fluid spills are cordoned off and cleaned up as soon as possible.			
Proper lighting is provided and is in good working order.			
Designated walkways are used and not obstructed.			
Proper footwear is provided and worn.			
The surfaces of trailers are free from damage or defect likely to cause a load to shift or fall, or to result in an accident to any person working on the trailer platform.			
Proper storage is provided for load restraint equipment.			

Section D: Slips, Trips and Falls (Continued)

List All Trucks Used			
Safety Practices			
Walk, don't run.			
Step down, don't jump.			
Walkways are kept clear.			
All areas are well lit.			
Oil/liquid spills are cordoned off and cleaned up immediately.			
The job is not finished until you have tidied up.			
Proper access ladders are used; never use boxes / barrels etc.			
If working at height use edge protection or a harness.			
Use three points of contact when accessing / egressing vehicle cabs or using vehicle ladders .			
Avoid parking near potholes and always look at the ground prior to getting out of the vehicle.			
Additional Controls			

Note: If a safety control measure is missing, indicate that on Your Action List on pages 112 and 113.

Section E: Training

Name of Driver	
I will ensure that:	
Employees receive necessary training and certification (where appropriate) and refresher training where required in respect of the following:	
Manual handling.	
Safe Pass Registration Card.	
First aid.	
Forklift driving.	
Crane operation.	
ADR Driver Training.	
Working at heights.	
Truck Mounted Conveyor.	
Safe vehicle access and egress.	
Drivers CPC training.	
Other specialist training as required.	
Additional Controls	

Note: If a safety control measure is missing, indicate that on Your Action List on pages 112 and 113.

Section F: Health

Name of Driver	
I will ensure that:	
Drivers know how to adjust their seats correctly in order to prevent or reduce back pain and ensure good ergonomics.	
Employees are aware of the risk of dermatitis caused by contact with cement, diesel or other chemicals and have appropriate personal protective equipment (PPE).	
Employees are made aware of noisy areas and that ear defenders are provided and worn.	
Employees are aware of the risks associated with dust especially silica dust and appropriate PPE is supplied and worn.	
Employees avoid manual handling where possible by ensuring that mechanical aids provided are used.	
Employees are aware of the risks associated with exposure to the sun, wear hats and sun cream when necessary and monitor their skin condition.	
Additional Controls	

Note: If a safety control measure is missing, indicate that on Your Action List on pages 112 and 113.

Part 3

Vehicle Specific-Safe Systems of Work and Risk Assessments

Introduction

In this section:

- Select the vehicle or operation that is relevant to you;
- Read the information and guidance provided in the safe system of work for your chosen vehicle or operation;
- Then complete the risk assessments that are relevant to you.



Section (a): Tipper Vehicle

Tipper Vehicle Operation: Safe System of Work

Specification

The Institute of Road Transport Engineers has set out a performance standard which companies should use when specifying tippers. Category A requires that a vehicle must be capable of staying stable on a side slope of at least 7° when loaded to the plated maximum gross vehicle weight and with its body fully raised.



Loading

The driver must ensure that:

- The vehicle body is inspected regularly to see if there is any material sticking in corners that could cause instability when the vehicle is tipped;
- The tailgate is securely closed once the load is discharged;
- He/she stays in the cab during loading;
- The material has been uniformly loaded and is not projecting above the side of the body; and
- The load is sheeted if required. This should be done from ground level or from a working platform and should not require the driver to climb onto the vehicle.

Unloading

The driver must ensure that:

- The appropriate PPE is worn before exiting the cab;
- The site traffic management system is observed;
- He/she checks with the Site Manager or Supervisor and obtains clear instructions on the exact location where the material should be offloaded;
- There are no overhead power cables in the area. Under no circumstances should a vehicle be tipped within 6 metres (20 feet) of 200Kv overhead power cables, within 4.5 metres (15 feet) of 100Kv cables or within 3 metres (10 feet) of all other lines;

- If there are overhead power cables on the site, the vehicle is outside the barrier;
- The ground condition is suitable for tipping (i.e. that it is firm and level and not likely to pose a risk to other personnel nearby or to the vehicle or other property);
- Having established that it is safe to tip, the vehicle is positioned at the location for tipping and that all wheels are straight;
- If the vehicle is an artic, the tractor unit is in line with the trailer;
- The handbrake has been applied;
- The cover is removed and secured in the open position and the tailgate is released. Any cover should be capable of being removed from ground level or from a working platform and should not require the driver to climb onto the vehicle;
- All other personnel and/or members of the public are clear of the immediate area;
- He/she returns to the cab and raises the body;
- If the load sticks or “hangs up” the body is lowered to enable the material to be loosened manually;
- Attempts to loosen the hung up material are not made by shunting the vehicle backwards and forwards with the body raised;
- If clearing the “hung up” material by getting into the body of the truck, a person is identified to prevent loading, preferably the driver of any loading equipment;
- If there is a danger of the vehicle overturning, the body is lowered immediately and the cause investigated;
- The vehicle only travels a few metres forward with the body raised to allow the material to discharge completely;
- Once the material is discharged, the body is lowered completely before moving off;
- The tailgate is closed securely;
- The site is exited safely; and
- The vehicle is never driven with a fully or partially raised body.

Note: Drivers should be aware of the limitations of their vehicle and the risk of overturning.



Tipper Vehicle Operation Risk Assessment

Tipper Vehicle	List All Trucks Used		
Vehicle Registration Number			
I will ensure that:			
The pre-start check has been carried out and documented (Appendix 2).			
Vehicles are not loaded beyond permitted maximum weights (Appendix 3)			
The tipping ram is free from leaks.			
Hydraulic/pneumatic lines/unions are checked for damage.			
Check valves are fitted and operational.			
The tipper body has not been unevenly loaded or overloaded.			
The tipper tailgate is operating correctly and closed securely immediately following discharge.			
Loading/tipping only takes place on stable/level ground.			
The driver is the only person to operate the tipping unit.			
No tipping takes place within 6 metres (20 feet) of 200Kv overhead power cables, within 4.5 metres (15 feet) of 100Kv cables or within 3 metres (10 feet) of all other lines.			
No tipping takes place close to personnel and/or members of the public.			
If tipping into a paver, the paver operator's instructions are followed.			

Tipper Vehicle Operation Risk Assessment

Tipper Vehicle	List All Trucks Used		
I will ensure that:			
Reversing cameras are fitted and operational.			
On-site traffic management and safety rules are followed.			
Flashing beacons are used while on site or as required.			
The tipper body is fully lowered after discharge.			
Appropriate PPE is worn on site.			
The truck is maintained as per the manufacturer's instructions.			
Where used on a public road, the truck is DOE tested annually.			
Defects are communicated to a responsible person.			
Safety Practices			
Never work under a raised tipper body unless mechanically propped.			
Never drive with the tipper body raised (except a short distance to aid discharge).			
Never raise the body near or under power lines.			
Only competent/licensed personnel drive and operate these trucks.			
The ground conditions are assessed before loading/tipping.			
Additional Controls			

Note: If a safety control measure is missing, indicate that on Your Action List on pages 112 and 113.



Articulated Vehicles: Safe System of Work

Articulated vehicles now represent a significant proportion of delivery vehicles. This is partly a result of the development of sliding bogies which allow the semi-trailer to be “shortened” for greater manoeuvrability on sites, while operating the vehicle at the requisite overall lengths to comply with axle spacing regulations thus allowing operation at maximum gross vehicle weight limits.

Coupling of Tractor and Semi-Trailer

The tractor and trailer should be compatible in order to ensure that the braking systems on the tractor and semi-trailer will work safely when coupled. The uncoupling and coupling of tractors and semi-trailers have resulted in a number of serious accidents, and the driver should observe the following procedures:

Uncoupling

First apply the park brake by pulling the red knob outwards. The spring brakes are now applied, and the driver can continue with normal uncoupling procedures;

Coupling

First check that the spring brakes on the trailer have been applied (i.e. check that the red knob is pulled out). Continue with the normal coupling procedure and, having first checked that the tractor’s handbrake is applied, push the red knob inwards to release the trailers spring brakes.

For further information see www.soe.org.uk/resources/technical-guides/

Section (b): Articulated Vehicle

Use of Sliding Bogie Trailers

When the vehicle is on the road, the trailer should be fully extended to ensure compliance with the relevant vehicle weight and dimensions regulations (See Appendix 3).

The vehicle may be “shortened” to improve manoeuvrability on site. Drivers should ensure that they follow the supplier’s instructions when extending or retracting the bogie and that the necessary locking pins are in place.

Rollovers

Research has shown that rollovers of articulated vehicles can occur at relatively slow speeds, particularly on roundabouts. Drivers should take care to ensure that they have reduced their speed sufficiently approaching roundabouts so as to avoid braking when turning.

Braking

Both the tractor unit and semi-trailer should be equipped with ABS (anti-lock braking system) .

Jackknifing

When the rear wheels of the tractor unit lock, the tractor swings around rapidly and there is no time for the driver to react to bring the vehicle back to stability. This creates a very dangerous situation. ABS brakes on the tractor unit can prevent jackknifing.

Semi-Trailer Swing

This occurs when the rear wheels of the trailer lock and the semi-trailer swings out. While trailer swing is not as sudden as jackknifing, because the swing out is slower, it is potentially very dangerous because the semi-trailer can hit other vehicles. ABS on the semi-trailer alone can prevent trailer swing but cannot prevent jackknifing.

Hence the importance of ensuring that both tractor and semi-trailer are equipped with ABS which are in working condition.



Tipper Vehicle Operation Risk Assessment

Articulated Vehicles

List All Trucks Used

Vehicle Registration Number			
I will ensure that:			
The pre-start check has been carried out and documented (Appendix 2).			
The vehicle is maintained in good condition.			
Both tractor and trailer are equipped with ABS (anti-lock braking system).			
The vehicle is not loaded beyond its maximum legal weight (Appendix 3).			
Coupling of Trailers			
Drivers are trained in coupling and uncoupling.			
The trailer parking brake is applied before coupling to a trailer.			
The fifth wheel locking mechanism is engaged (by trying to drive forwards in low gear) after coupling.			
The parking brake is applied on the tractor unit.			
The engagement of the fifth wheel is visually checked and the safety clip is put in place.			
The air lines and electrical suzies are connected to the trailer.			
The landing legs are wound up and the handle secured.			
The trailer parking brake is released.			
The number plate is fitted and the lights are checked.			
Uncoupling of Trailers			
The ground is firm and level enough to support both landing legs.			
The parking brake on the trailer is applied.			
The air lines and electrical suzies are disconnected.			
The landing legs on the trailer are wound down and the handle secured.			
The locking mechanism on the fifth wheel is disengaged.			

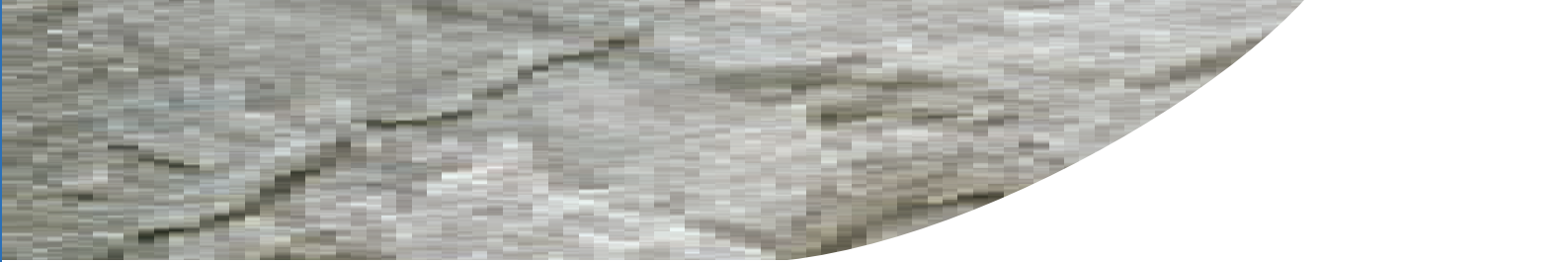

Articulated Vehicles

List All Trucks Used

Uncoupling of Trailers

The tractor is driven out from under the trailer safely.

Parking

The vehicle is parked in a safe place and does not pose a hazard to other traffic or pedestrians.

The parking brake has been applied.

Load Security

Loads are properly secured on the trailer.

The load security is rechecked after five kilometres travel.

If the load is liable to move it is checked periodically during transportation.

Loading

The driver is not allowed operate equipment such as forklifts unless trained and certified to do so.

The driver is not allowed drive plant onto the trailer unless trained and certified to do so.

Sliding Bogie Trailers

Drivers are trained in the operation of sliding bogie trailers.

When driving on the road the sliding bogie trailer is fully extended to ensure compliance with the relevant vehicle weight and dimensions regulations.

Load Height

The route is checked to ensure that there are no overhead lines or low bridges which might be struck by the vehicle or its load.

Appropriate permits are in place for the transportation of abnormal loads.

Additional Controls

Note: If a safety control measure is missing, indicate that on Your Action List on pages 112 and 113.



Section (c): Bulk Cement Vehicle

Bulk Cement Vehicle: Safe System of Work

Loading

- The appropriate PPE is worn;
- The safety rail is raised before climbing onto the top of the tanker;
- The tanker has been decompressed;
- The man lid is opened;
- The appropriate grade of cement is selected and loaded;
- The man lid is closed securely; and
- The vehicle is driven through the wash to remove any cement dust from the vehicle.

Note: It is recommended that a safety rail is provided on both sides of the top of the tanker or some other suitable means of fall prevention/fall arrest.

Discharge

The driver must ensure that:

- The appropriate PPE, including eye and ear protection is worn;
- The silo has the capacity to receive the quantity you are discharging;
- The discharge hose is connected to the outlet pipe on the tanker;
- The storage filtration system is turned on and is working properly;
- If using an electrical motor to operate the compressor, the cable is carefully connected to the socket, the power is turned on and the compressor is started;

- If a donkey engine is being used, the engine and compressor are started;
- The air valves are operating to discharge the product;
- The pressure gauges are monitored to ensure that the pressure does not exceed the safe working pressure;
- At the end of the discharge, the air pressure in the tanker is released (the vehicle must not be driven with a pressurised tank);
- He/she stays in attendance at all times during the discharge and is prepared to shut down the discharge in case of emergency such as a full silo or hose failure; and
- Air pressure is fully released before discharge pipes are disconnected.

Note: Should a hose burst or blow off, a driver could suffer serious injuries if he/she is not wearing adequate personal protective equipment.

Tanker Pressure Build Up

There have been a number of incidents where the tanker shell has exploded. Drivers should take the following precautions prior to commencing discharge.



Pressure Gauges and Relief Valves

Check the pressure gauges. Ensure that they can be read and are reading accurately. This can be verified by ensuring that the gauge drops to zero when the tanker is empty. If in doubt have the gauges replaced immediately.

Pressure Relief Valves

Pressure test all safety relief valves and ensure that the valve is opening at the maximum safe working pressure. While the safe working pressure is 2 bar for most modern tanks, the test plate should be checked to verify the figure as a different pressure may apply to some tanks.

To test the pressure valve in place, close all valves leading to the tanker except the valve isolating the pressure relief valve (if fitted). Run the compressor and allow air to build up in the pipeline. Check that the pressure relief valve opens and record the pressure.

If in doubt have the pressure relief valve replaced immediately. **Do not attempt to operate the tanker with a faulty pressure relief valve.**



Bulk Cement Vehicle Risk Assessment

Bulk Cement Vehicle	List All Trucks Used		
Vehicle Registration Number			
I will ensure that:			
.....			
The pre-start check has been carried out and documented (Appendix 2).			
.....			
Drivers are supplied with and wear the following PPE in addition to the regular PPE:			
.....			
- Eye protection (either goggles or visor);			
.....			
- Ear defenders.			
.....			



Bulk Cement Vehicle

List All Trucks Used

Loading

Drivers are trained in the operation of cement tankers before being allowed operate on their own.

The safety rail is raised before accessing the top of the tanker.

The tanker is decompressed before opening the man lids.

Man lids are securely closed after the tanker is loaded.

Any cement dust is washed off the vehicle before leaving the site.

Vehicles are not loaded beyond permitted maximum weights (Appendix 3).

Discharge

The receiving silo is checked to ensure it has adequate capacity to receive the quantity being discharged.

The discharge hose is securely connected to the silo and the outlet pipe on the tanker.

If using electrical power the cable is carefully connected to the socket on the tanker.

If using a donkey engine, the engine and compressor are started.

The pressure relief valve is tested before the tanker is pressurised.

The air pressure gauge is monitored to ensure that the safe working pressure is not exceeded.

At the end of the discharge, the tank is depressurised (The tanker must not be driven on the road in a pressurised condition).

The driver stays in attendance at all times during the discharge, at the controls or rear of the vehicle.

Bulk Cement Vehicle

List All Trucks Used

Discharge

When the high-level cement silo alarm is activated discharge ceases immediately and the driver reports to the Plant Manager for further instruction.

Air pressure is fully released before discharge pipes are disconnected.

Maintenance

The tanker is maintained in a safe and road-worthy condition and complies with all statutory requirements.

The tanker vessel is inspected at the required intervals as specified by a competent person.

Hoses are monitored and replaced as necessary.

Additional Controls

Note: If a safety control measure is missing, indicate that on Your Action List on pages 112 and 113.



Section (d): Mortar Silo

Mortar Silo: Safe System of Work

Silo Delivery

The driver must ensure that:

- The appropriate PPE is worn;
- The site traffic management system is observed;
- The ground has been prepared and is suitable to erect the silo;
- There are no overhead cables within 6 metres (20 feet) of the silo base;
- The stabilisers on the vehicle are extended;
- The silo is carefully removed from the vehicle and erected on site;
- The stabilisers are retracted; and
- The site is exited safely.



Silo Removal

The driver must ensure that:

- The appropriate PPE is worn;
- The site traffic management system is observed;
- There are no overhead cables within 6 metres (20 feet) of the site;
- The vehicle is positioned as close as possible to the silo;
- The stabilisers are extended on the vehicle;
- The silo is lowered onto the vehicle and secured;
- The stabilisers are retracted; and
- The site is exited safely.

Silo Filling

The driver must ensure that:

- The appropriate PPE is worn;
- The site traffic management system is observed;
- He or she checks in with the Site Manager or Supervisor;
- The vehicle is parked safely. Where possible the vehicle should be parked on site while observing all site safety rules. If it is necessary to park on the road, ensure that the vehicle is “coned off” and that the site safety personnel provide assistance in directing traffic and pedestrians;
- The hoses are connected to the silo and the filter bag to the vent pipe;
- The compressor is started and the mortar is discharged into the silo;
- He/she stays in attendance at all times to monitor the discharge;
- After discharge, all hoses and equipment are removed and stowed securely on the vehicle;
- The tank has been fully vented; and
- The site is exited safely.



Mortar Silo

List All Trucks Used

Vehicle Registration Number

I will ensure that:

The pre-start check has been carried out and documented (Appendix 2).

Drivers are supplied with and wear the following PPE in addition to the regular PPE:

- Eye protection (either goggles or visor);
- Ear defender.

Drivers are competent in the operation of silo mortar tankers before being allowed operate on their own.

Loading Product in Depot

The tanker is decompressed before opening the man lids.

Suitable fall protection system is in place for access to top of tanker (e.g. raised safety rail or inertia reel system).

Man lids are securely closed after the tanker is loaded.

Discharge of Mortar into Site Silo

Appropriate PPE is worn.

On-site traffic management and safety rules are followed.

Mortar Silo	List All Trucks Used		
I will ensure that:			
Discharge of Mortar into Site Silo			
Driver checks with Site Manager/Supervisor to ensure that receiving silo has been checked to ensure that it has adequate capacity to receive the quantity being discharged.			
The tanker is parked as close as possible to the silo location whilst obeying site traffic rules. (If it is necessary to park on the road the driver and site personnel must ensure the vehicle is "coned off").			
The discharge hose is securely connected to the silo and the outlet pipe on the tanker.			
The filter bag is connected to the silo vent pipe.			
The driver stays in attendance at the tanker to monitor the complete discharge process.			
When the bag or pressure starts to drop discharge ceases immediately.			
After discharge all hoses and equipment are removed and stored on the vehicle.			
Delivery of Silo			
Appropriate PPE is worn.			
Drivers consults with site personnel on the requested location of the silo.			
Silo location is suitably prepared and level.			
Drivers check that no overhead cables are within 6 metres (20 feet) of the silo base.			
Drivers extend vehicle stabilisers prior to carefully removing the silo from the truck and placing it.			
Drivers retract stabilisers before exiting the site.			
Silo operating procedures are given to the customer prior to mortar being dispensed from silo.			



Mortar Silo

List All Trucks Used

Removal of Silo

Appropriate PPE is worn.

Drivers check that no overhead cables are within 6 metres (20 feet) of the silo base.

Drivers ensure all electrical and water connections have been removed from the silo.

Drivers position the vehicle as near as possible to the silo before extending stabilisers.

Drivers lower the silo onto the vehicle and secure it before exiting site.

Drivers retract stabilisers.

Maintenance

The tanker is maintained in a safe and roadworthy condition and complies with all statutory requirements.

The tanker vessel is inspected at the required intervals as specified by a competent person.

Silo delivery hoses are maintained and replaced as necessary.

Additional Controls

Note: If a safety control measure is missing, indicate that on Your Action List on pages 112 and 113.



Section (e): Concrete Mixers

Concrete Mixers: Safe System of Work

Specification

It is essential that there is communication between the mixer supplier and vehicle supplier at an early stage in the vehicle specification process to ensure that the mixer is mounted on the vehicle to optimise load distribution.

Loading

The driver must ensure that:

- The vehicle is not overloaded or the drum is not overfilled or overloaded;
- The water tank has sufficient water for cleaning after discharge; and
- He/she is aware of nip points at discharge chute and receptor.

Transportation

Drivers should take all reasonable care to prevent spillages, particularly on bends, roundabouts, steep hills and slip roads. Where any spillage occurs, drivers should report this immediately. The relevant company must respond promptly and take the necessary remedial action.

Discharge

The driver must ensure that:

- The appropriate PPE is worn;
- He/she checks in with the Site Manager or Supervisor;
- The site traffic management system is observed;

- He/she does not permit any other person to lower the discharge chutes or operate the controls;
- The material is discharged as requested;
- If the customer is unable to take the entire load, the office or Supervisor is contacted before product is returned;
- After discharge the chutes are washed and stowed safely on the vehicle; and
- The site is exited with particular attention paid to pedestrians, cyclists and the speed of oncoming traffic.

Product Safety

- Fresh mortar, renders and screeds contain cement and water with the result that an alkaline solution is produced;
- Prolonged skin contact with wet mortar, renders and screeds can result in cement burns. The abrasiveness of the constituents can aggravate the effect.



Mixer Trucks with Conveyor Belts

A small number of mixer trucks have conveyor belts attached to facilitate delivery of concrete over longer distances; these require trained experienced operators who must ensure that:

- The conveyor belt does not strike personnel on the site; and
- The conveyor belt is not operated within 6 metres (20 feet) of overhead 200Kv cables, within 4.5 metres (15 feet) of 100Kv cables or within 3 metres (10 feet) of all other lines. (See pages 13 to 16).

(Further guidance is provided in the ESB Networks *Code of Practice for Avoiding Danger from Overhead Electricity Lines* (2008))



Surplus Concrete Returns

Mixed concrete has a very short shelf life and must be used while in a workable state, generally within two hours of production. Returned concrete may be outside the optimum workable state when it is returned to the supplier and, therefore, cannot be redirected to another customer. Environmental legislation demands the careful management, recycling and/or disposal of this product. Where the customer cannot take all the product ordered, the driver should contact his Supervisor to get instructions on how to handle the surplus product before leaving the customer’s site.

Cleaning of Mixer Chutes

Most sites allow drivers to wash down chutes after delivery. A designated area which is safe and away from other vehicles should be provided. Drivers should ensure that all waste water arising from the cleaning remains on site and does not flow onto the roadway or into site drains.



Concrete Mixer Risk Assessment

Concrete Mixer

List All Trucks Used

Vehicle Registration Number

I will ensure that:

The pre-start check has been carried out and documented. (Appendix 2).

Reversing cameras are fitted and in good working order.

The driver has received training in the operation of the mixer controls.

On-site traffic management and safety rules are followed.

Vehicle Registration Number			
I will ensure that:			
The pre-start check has been carried out and documented. (Appendix 2).			
Reversing cameras are fitted and in good working order.			
The driver has received training in the operation of the mixer controls.			
On-site traffic management and safety rules are followed.			

Concrete Mixer

List All Trucks Used

I will ensure that:

Flashing beacons are used on site or as required by Site Management.

Appropriate PPE is worn on site.

The truck is serviced and maintained as per the manufacturer's instructions.

The truck is DOE tested annually.

Defects are communicated to a responsible person.

The mixer is not loaded beyond its maximum legal weight. (Appendix 3).

Only the driver operates chutes and controls.

Brakes are on/engaged prior to leaving the vehicle.

Loading at the Concrete Plant

Plant Manager instructions are followed.

The vehicle can be manoeuvred without endangering personnel or equipment.

The vehicle is secure before leaving the cab.

Drum charge lever is engaged.

Hand throttle is engaged to required drum revolutions.

Once the vehicle is loaded any spillage is removed from the rear of the vehicle before leaving the plant.

Offloading at the Customer Site

The vehicle can be manoeuvred safely on site.

Overhead obstructions are checked.

Vehicle is on level/solid ground before discharging.

Discharge chutes are positioned carefully over the discharge point (i.e. pump, skip, etc).

Concrete Mixer

List All Trucks Used

I will ensure that:

The driver is the only person permitted to lower the discharge chutes or operate the controls.

Instructions from site personnel on the manner in which discharge is to be executed are followed.

Drum discharge lever is engaged.

Hand throttle and/or electronic throttle is engaged to required drum revolutions.

Discharge is in accordance with site management instructions.

Care is exercised to avoid overfilling of receptors.

When discharge is complete

All discharge chutes are secured in their fixing position before proceeding to the designated wash down area.

The mixer is cleaned down in the designated area.

When washing down drum and chute with chemical cleaning agents, goggles, gloves and masks are worn and running water is available at all times.

Concrete Truck Mounted Discharge Conveyors

I will ensure that:

The driver has received training in the operation of the conveyor.

Flashing beacons are used on site or as required by Site Management.

A visual check is made on the conveyor before operation.

Emergency stop buttons are working effectively.

Concrete Truck Mounted Discharge Conveyors

I will ensure that:

All nip points at head and tail drum are effectively guarded in accordance with manufacturer's instructions.

No site personnel are working underneath the area where the conveyor is working.

The truck is never driven with the conveyor in the raised position.

The conveyor is not operated within 6 metres (20 feet) of 200Kv overhead power cables within 4.5 metres (15 feet) of 100Kv cables or within 3 metres (10 feet) of all other lines.

When working on or near public roads, traffic lines are adequately controlled by the contractor.

When operating through openings a competent banksman is supplied by the contractor.

The conveyor is never used as a crane.

The conveyor is serviced and maintained in accordance with the manufacturer's instructions.

Defects are communicated to a responsible person.

Additional Controls

Note: If a safety control measure is missing, indicate that on Your Action List on pages 112 and 113.



Section (f): Block Delivery Truck

Block Delivery Truck Operation: Safe System of Work

Loading

Note: Side creels must be fitted on all block trucks.

The driver must ensure that:

- The appropriate PPE is worn;
- The load is uniformly distributed. If it is not, this may result in instability and/or axles being overloaded;
- Bales of blocks are strapped; any bales with broken or missing straps are rejected. Note: strapping is only designed to facilitate handling activity during manufacture and should not be relied to provide stability of bales during transport, site handling or storage;
- The side creels are closed after loading and the load is secure;
- When the loading is complete, the crane is stowed safely;
- Under no circumstances is the crane used for lifting personnel; and
- The vehicle is never moved with the crane in the raised position.

OffLoading

The driver must ensure that:

- The appropriate PPE is worn;
- The site traffic management system is observed;
- He/she checks with the Site Manager or Supervisor and obtains clear instructions on the exact location where the blocks should be placed;
- Blocks are not offloaded directly onto scaffolding, unless the scaffolding has specially designated loading bays;
- A load is not left suspended from the crane;
- The load is not lifted over people;
- There are no overhead power cables in the unloading area. Under no circumstances should the crane be operated within 6 metres (20 feet) of 200Kv overhead power cables, within 4.5 metres (15 feet) of 100Kv cables or within 3 metres (10 feet) of all other lines;
- If working on or near a public road, members of the public and traffic lanes are adequately protected by the contractor;
- A visual check is carried out to establish suitability for unloading;
- The vehicle is positioned as close as possible to where the blocks are to be offloaded;
- Both stabilisers are extended and stabiliser pads are fitted underneath the legs as required;
- The side creels are lowered;
- The operating position for the crane is accessed safely using the ladders and steps provided;
- There are no personnel within the working area of the crane. If necessary seek assistance from the Site Manager or Supervisor;
- When the offloading is complete, the crane is stowed safely, the stabilisers are retracted, the stabiliser pads are stowed and the side creels are closed;
- The site is exited safely;
- Under no circumstances is the crane used for lifting personnel; and
- The vehicle is never moved with the crane in the raised position.



Block Delivery Truck Operation Risk Assessment

Block Delivery Truck	List All Trucks Used		
Vehicle Registration Number			
I will ensure that:			
The pre-start check has been carried out and documented. (Appendix 2).			
The truck is DOE tested annually.			
The truck is serviced and maintained as per the manufacturer's instructions.			
Block grab rubbers are checked daily for damage.			
The crane is checked daily for hydraulic leaks.			
The crane is tested and certified every 12 months by an independent engineer.			
The crane is fitted with overload protection to prevent the safe working load for the relevant radius being exceeded.			
The crane is maintained by a competent person.			
The access ladder to the crow's nest is maintained in good condition.			
Only trained and competent drivers operate the truck mounted crane.			
Side creels are fitted and used on all trucks.			
Site traffic management and safety rules are followed.			
The surfaces of trailers are free from damage or defect likely to cause a load to shift or fall or to result in an accident to any person working on the trailer platform.			
Loading			
Blocks are loaded by trained drivers and in accordance with the Plant Manager's instructions.			
Drivers inspect loads prior to leaving the yard and any damaged bales are removed and replaced.			

Block Delivery Truck Operation Risk Assessment Contd

Block Delivery Truck

List All Trucks Used

Loading:

Block truck side creels are secured in place after loading.

The block truck is not loaded beyond its maximum legal weight. (Appendix 3).

The consignment is secured prior to leaving the yard.

Unloading

Flashing beacons are used while on site or as required.

The truck is never driven with the crane in the raised position.

No offloading of blocks takes place within 6 metres (20 feet) of 200Kv overhead power cables, within 4.5 metres (15 feet) of 100Kv cables or within 3 metres (10 feet) of all other lines.

The driver checks the ground to ensure it is level and suitable prior to offloading.

The driver positions the crane as close as possible to offloading location to minimise crane slewing distance and to maximise the view of the operation area.

The driver extends both stabilisers on boards before starting any offloading.

The driver ensures that no site personnel are working underneath the area where the crane is moving with blocks in the crane grab.

The driver only unloads blocks under instruction from the Site Supervisor.

The driver never offloads blocks directly onto scaffolding.

If instructed to load blocks onto structures then the driver checks with Site Supervisor that the structure is suitable for the weight of the blocks being offloaded and clear of personnel.

Additional Controls

Note: If a safety control measure is missing, indicate that on Your Action List on pages 112 and 113.



Section (g): Truck Mounted Cranes

Truck Mounted Crane (Lorry Loader): Safe System of Work

Specification

All cranes should be installed in accordance with the Association of Lorry Loader Manufacturers and Importers (ALLMI) Code of Practice for Installation, Application and Operation of lorry loaders.

Use

When siting the truck mounted crane take account of:

- The standing and support conditions;
- The presence and proximity of other hazards such as people or overhead power lines;
- The effect of environmental conditions such as the wind;
- The adequacy of access to allow the positioning and set up of the lorry loader for the lifting operation;
- Further information see British Standard BS 7121-4:2010: *Code of Practice for Safe Use of Cranes – Part 4: Lorry Loaders*.



Truck Mounted Crane

List All Trucks Used

Vehicle Registration Number

I will ensure that:

The pre-start check has been carried out and documented before each shift. (Appendix 2).

The truck is DOE tested annually.

The truck is serviced and maintained as per the manufacturer's instructions.

Block grab rubbers are checked daily for damage.

The crane is checked daily for hydraulic leaks.

The crane is tested and certified every 12 months by an independent engineer.

The crane is fitted with overload protection to prevent the safe working load for the relevant radius being exceeded.

The crane is maintained by a competent person.

The access ladder to the crow's nest is maintained in good condition.

Only trained and competent drivers operate a truck mounted crane.

Side creels are fitted to all trucks.

Site traffic management and safety rules are followed.

The surfaces of trailers are free from damage or defect likely to cause a load to shift or fall or to result in an accident to any person working on the trailer platform.

Truck Mounted Crane

List All Trucks Used

Loading

The appropriate PPE is worn

Precast units are loaded by trained drivers and in accordance with the Plant Manager's instructions.

Drivers inspect loads prior to leaving the yard, and any damaged material is removed and replaced.

Truck side creels are secured in place after loading.

The truck is not loaded beyond its maximum legal weight.

The consignment is secured prior to leaving the yard.

Unloading

The appropriate PPE is worn

Flashing beacons are used while on site or as required.

The truck is never driven with the crane in the raised position.

No offloading of precast products takes place within 6 metres (20 feet) of 200Kv overhead power cables, within 4.5 metres (15 feet) of 100Kv cables or within 3 metres (10 feet) of all other lines.

The driver checks ground conditions to ensure it is level and suitable prior to offloading.

The driver positions the crane as close as possible to the offloading location to minimise crane slewing distance and to maximise the view of operation area.

The driver extends both stabilisers on boards before starting to offload.

The driver ensures that no site personnel are working underneath the area where the crane is moving with precast units in the grab.

The driver only unloads precast units under instruction from the Site Supervisor.

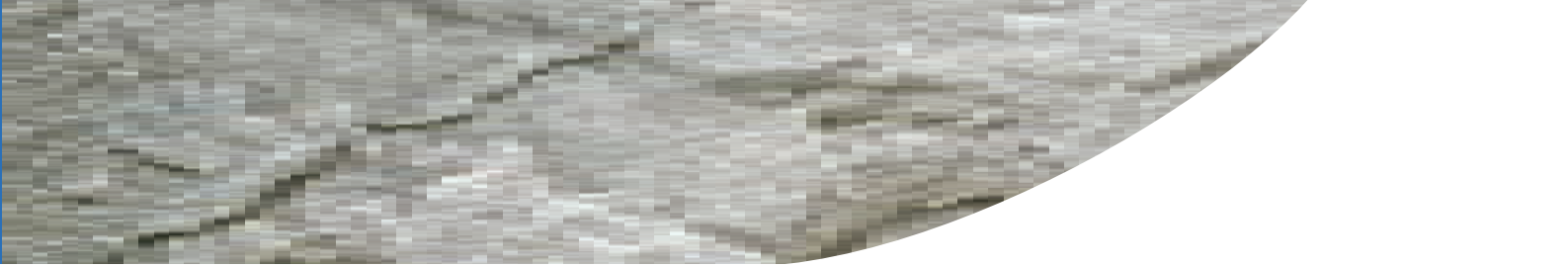

Truck Mounted Crane

List All Trucks Used

Unloading

The driver never offloads precast units directly onto scaffolding.

If instructed to load precast units onto structures then the driver will check with the Site Supervisor that the structure is suitable for the weight of the precast units being offloaded and is clear of all personnel.

Additional Controls

Note: If a safety control measure is missing, indicate that on Your Action List on pages 112 and 113.



Section (h): Blacktop Rigid Vehicle

Blacktop Rigid Vehicle: Safe System of Work

Loading

The driver must ensure that:

- The load is uniformly distributed;
- The load is covered and tied down securely; and
- The vehicle is not overloaded.

Discharge

The driver must ensure that:

- The appropriate PPE is worn;
- The site traffic management system is observed, including one way traffic systems or other stop-go systems;
- He/she watches out for any overhead cables: the vehicles should not be tipped within 6 metres (20 feet) of 200Kv cables, within 4.5 metres (15 feet) of 100Kv cables or within 3 metres (10 feet) of all other lines;
- Special care is taken when tipping/moving on wet or steep roads and when operating vehicles near pedestrians or excavations;
- When requested to reverse slowly to the spreader, once contact is made with the rollers on the spreader, the vehicle is stopped and the tailgate released;
- When a signal is received from the operator controlling the operation, he/she starts to tip the load;
- The gear lever is put into neutral, the handbrake is released and the vehicle is allowed to be pushed along by the spreader;
- He/she is ready to stop the vehicle at all times with the footbrake;
- He/she watches out for instruction from the operator in control;
- Once the load is discharged, the body is lowered and the tailgate is closed;
- Any surplus material is discharged at the designated area on site; and
- The site is exited safely.

Note 1: Drivers should be aware of the limitations of their vehicle and the risk of overturning.

Note 2: Overhead power lines are particularly hazardous on blacktop sites and road maintenance, because of the movement of the vehicles. Consider the need for overhead line proximity detection devices / alarms. (See page 13)

Note 3: Also, beware of any cables running parallel to the area being paved.

Product Safety

- Hot bituminous materials may burn skin; and
- Fumes from hot bituminous materials may be a risk to health with prolonged inhalation in confined spaces (e.g. tunnels). Adequate ventilation must be provided in enclosed areas.

Blacktop Rigid Vehicle Risk Assessment

Blacktop Rigid Truck

List All Trucks Used

Vehicle Registration Number

I will ensure that:

The pre-start check has been carried out and documented. (Appendix 2).

The tipping ram is free from leaks.

Hydraulic/pneumatic lines/unions are checked for damage.

Check valves are fitted and operational.

The tipper body has been loaded from the front, then the rear and then the middle, and has not been overloaded.

Automated or 'rollover' covers which can be sheeted from ground level are used and, where these are not fitted, platforms are used.

The tipper tailgate is operating correctly and closed securely immediately following discharge.

Loading/tipping only takes place on stable/level ground.

The driver is the only person to operate the tipping unit.

The tipper is not operated within 6 metres (20 feet) of 200Kv overhead power cables, within 4.5 metres (15 feet) of 100Kv cables or within 3 metres (10 feet) of all other lines.

No tipping takes place close to personnel.

Reversing cameras are fitted and operational.

On-site traffic management and safety rules are followed.

Flashing beacons are used while on site or as required.

The tipper body is fully lowered after discharge.

Blacktop Rigid Truck

List All Trucks Used

I will ensure that:

Appropriate PPE is worn on site.

The truck is maintained as per the manufacturer’s instructions.

Where used on a public road, the truck is DOE tested annually.

Defects are communicated to a responsible person.

Vehicles are not loaded beyond permitted maximum weights. (Appendix 3).

At the Spreader

Vehicle operations only take place under the clear instruction of the designated control person.

Once contact is made with the rollers on the spreader, the vehicle is stopped and the tailgate released.

Where the tipper is not fitted with an automatic tailgate, the tailgate is released from the side of the tipper/spreader.

The gear lever is put into neutral, the handbrake is released and the vehicle is allowed to be pushed along by the spreader.

Once the load is discharged, the body is lowered and the tailgate is closed.

Cleaning

Appropriate PPE is worn.

Biodegradable release agents are used for cleaning where possible.

No cleaning of body/tailgate takes place in spreader lane.

Cleaning will only take place in the designated cleaning area.

Blacktop Rigid Truck

List All Trucks Used

Safety Practices

Drivers never work under a raised tipper body unless it is mechanically propped.

Drivers never drive with the tipper body raised (except a short distance to aid discharge).

Drivers never raise the body near or under power lines.

Only competent/licensed personnel drive and operate trucks.

The ground conditions are assessed before loading / tipping.

Drivers never stand between the open tail board and the rear of the vehicle when the body is in a raised position.

Additional Controls

Note: If a safety control measure is missing, indicate that on Your Action List on pages 112 and 113.



Section (i): Bitumen Tanker Vehicle

Bitumen Tanker Vehicle Operation: Safe System of Work

Bitumen is classified as a hazardous substance under the Carriage of Dangerous Goods Regulations and is a specialist transport sector. The detailed requirements are set out in S.I.s 405 and 406 of 2006 and ADR. The following is a summary of the requirements:

Tractor Unit	ADR inspection (annual)
Tractor Unit	ADR inspection (annual)
Tanker	Tank pressure test (three years)
Equipment	Two fire extinguishers (minimum 12 kg) Two warning triangles Torch Wheel chock High Visibility vest Other equipment as required in the instructions in writing
Driver	ADR driver training certificate (renewable every five years) Personal protection as required
Vehicle Marking	Orange plates 99/3257 front and rear ADR no. 9 diamond and high temperature sign on both sides and rear
Documentation	Transport document detailing product, quantity, consignor and consignee

Instructions in Writing

Must provide details of actions in the event of an emergency

Bitumen is hazardous: it is transported at a very high temperature of 180°C and could cause serious burns were a person to come into contact with it.

Loading

Loading is carried out at the bitumen terminal. The method will vary from terminal to terminal, but either the driver carries out the loading himself or the terminal staff will do the loading. If the driver is required to carry out the loading, he or she must receive training from the terminal on the procedures.

Before leaving the bitumen terminal, the driver should ensure that:

- The correct grade of bitumen has been loaded;
- All man lids and outlet valves are closed;
- The vehicle is marked and placarded in accordance with the Regulations;
- The equipment on board (e.g. fire extinguishers etc.) is in order; and
- He/she has the necessary documentation.

Offloading

The bitumen storage facility should ensure that:

- There is an emergency shower in operational condition within a maximum of 20 metres of the discharge point;
- There is sufficient ullage in the tank to take the load being delivered plus 10%; and
- The tank fill pipe is identified with a grade tag.

The driver should ensure that:

- The appropriate PPE, including gauntlets, helmet with visor and neck cape, rubber boots and single piece overalls, is worn;
- The vehicle is weighed in (if required);
- The vehicle is parked at the delivery point. The vehicle should be level or sloping towards the rear;

- There is unrestricted access around the vehicle, and personnel not involved in the delivery are not allowed within 6 metres (20 feet) of the area;
- The hose is connected to the receiving tank first and then to the road tanker;
- The outlet valves on the tanker are opened and vent valve or man lid are opened to ensure the tank is suitably vented. Discharge may be by gravity, compressed air or pump;
- He/she and the receiver stay in attendance and monitor the delivery from a safe distance;
- If any leak is detected, the discharge is stopped, all valves are closed and the tanker is depressurised before any attempt to repair the leak is carried out;
- Under no circumstances should a driver or any other person attempt to carry out repairs on a pipe or hose while bitumen is being offloaded;
- On completion of discharge, the delivery hose is disconnected (road tanker end first); and
- If the bitumen has been offloaded using compressed air, the road tanker is fully depressurised before leaving the site.

Note: If the driver has to access the top of the tanker, suitable fall protection must be provided.



Bitumen Tanker Vehicle Operation Risk Assessment

Bitumen Tanker Vehicle	List All Trucks Used		
Vehicle Registration Number			
I will ensure that:			
The pre-start check has been carried out and documented. (Appendix 2).			
ADR Requirements are complied with.			
The following is a summary of the requirements:			
1. Tractor Unit: ADR Inspection (Annual).			
2. Tanker: ADR Inspection (Annual); Tank Pressure test (Every 3 years).			
3. Equipment: 2 fire extinguishers (min. 12 kg); 2 warning triangles; torch; wheel chock. High Visibility vest; other equipment as required in the instructions in writing			
4. Driver: ADR driver training certificate (renewable every 5 years;) PPE as required;			
5. Vehicle Marking: Orange Plates 99/3257 front and rear; ADR no. 9 diamond and high temperature sign on both sides and rear.			
6. Documentation: transport document detailing product, quantity, consignor and consignee;			
7. Instructions in writing listing details of actions in the event of an emergency.			

Bitumen Tanker Vehicle	List All Trucks Used		
I will ensure that:			
Drivers are supplied with and wear the following PPE in addition to regular PPE: <ul style="list-style-type: none"> - Gauntlets; - Helmet with visor and neck cape; - Steel toecap rubber boots; - Single piece overall. 			
Drivers are competent in the operation of bitumen tankers before being allowed to operate them on their own.			
Loading			
Only competent personnel are involved in the loading process.			
All bitumen terminal procedures are followed.			
The correct grade of bitumen has been loaded.			
All man lids and outlet valves are closed.			
The vehicle is marked and placarded in accordance with the Regulations.			
All the necessary equipment is on board and fully operational.			
All relevant documentation is on board.			
Vehicles are not loaded beyond permitted maximum weights. (Appendix 3).			
Unloading			
Clear instructions are obtained on the exact location where the load is to be placed.			
Appropriate PPE is worn on site.			
Site transport and safety rules are obeyed.			
The driver checks that the emergency shower is in an operational condition prior to unloading.			

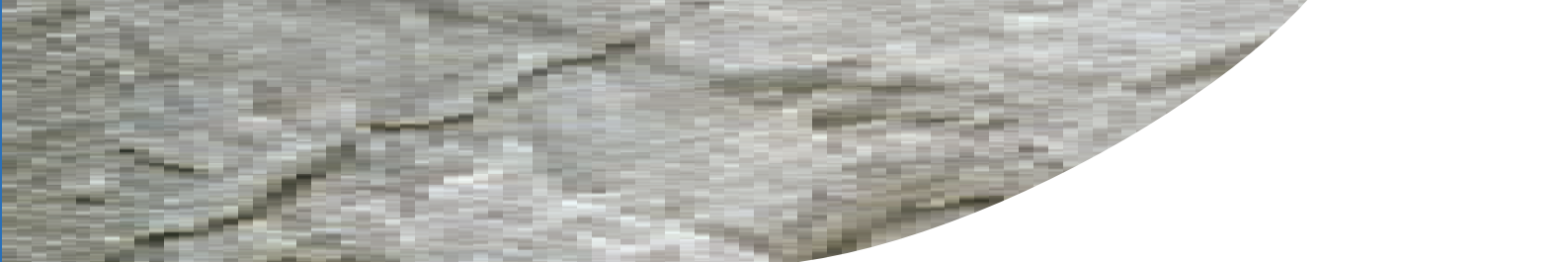

Bitumen Tanker Vehicle

List All Trucks Used

Unloading

The vehicle when parked at the delivery point will be level or sloping towards the rear.

There is unrestricted access around the vehicle.

Personnel not involved in the delivery are not within 6 metres (20 feet) of the area.

The hose is connected to the receiving tank first and then to the road tanker.

The outlet valves on the tanker are opened and the vent valve or man lid are opened to ensure the tank is suitably vented.

Throughout discharge, the delivery is monitored from a safe distance.

On completion of discharge, the delivery hose is disconnected (road tanker end first).

If the bitumen has been discharged using compressed air, the tanker is fully depressurised before leaving the site.

Maintenance

No maintenance or repairs are undertaken while bitumen is being offloaded.

Hoses are monitored and replaced as necessary.

Safety Practices

Appropriate PPE is worn at all times.

Only competent and licensed personnel drive and operate tankers.

Additional Controls

Note: If a safety control measure is missing, indicate that on Your Action List on pages 112 and 113.



Section (j): Precast Concrete Delivery

Precast Concrete Delivery: Safe System of Work

Loading:

In exceptional cases vehicles carrying precast concrete will exceed the maximum allowable vehicle dimensions for road transport and permits will be required to transport the products to their destination.

Maximum allowable:

Width: the maximum width of an overhanging load is 2.9 metres (9 feet 6 inches) and the maximum projection on either side of the vehicle is 305 millimetres (1.2 inches).

Length: the load on a vehicle must not project more than 3 metres (10 feet) beyond the rearmost point of the vehicle or trailer. If the load projects more than 1 metre (3 feet 4 inches), a warning device must be carried.

Height: while there is no maximum height for vehicles, where the load is of exceptional height, the company should survey the route to be taken and ensure that there are no low bridges and that the load will not come in contact with overhead cables.

The maximum vehicle weights are given in Appendix 3 and must never be exceeded.

Applications for permits should be made to the appropriate Local Authority/ies and should describe the vehicles for which the permits are required, the nature, dimensions and weight of any load or loads to be carried, details of the journey or journeys to be undertaken and other information as requested by the Local Authority/ies. In addition a new system has been put in place for permits for vehicles exceeding the maximum dimensions on national primary routes requiring seven days notice to An Garda Síochána. (S.I. No. 147 of 2009).



Where it is unavoidable and drivers have to climb onto loads to attach or remove chains or slings, suitable protection against falls should be put in place as required by Part 4 (Work at Height) of the General Application Regulations 2007 (S.I. No. 299 of 2007) as amended. Drivers should take particular care when working on trailer decks.

Load Security

The load should be secured using chains and tensioners, while ensuring that the precast product is not damaged or stressed. The load security should be checked during the journey. Drivers should ensure that all chains, tensioners and strapping are secure and do not pose a risk to other road users. Check load restraint equipment for damage, wear and tear every time you use it. Ensure that it is marked to show the load it is rated for.

Guidance on the Loading of Precast Concrete Units

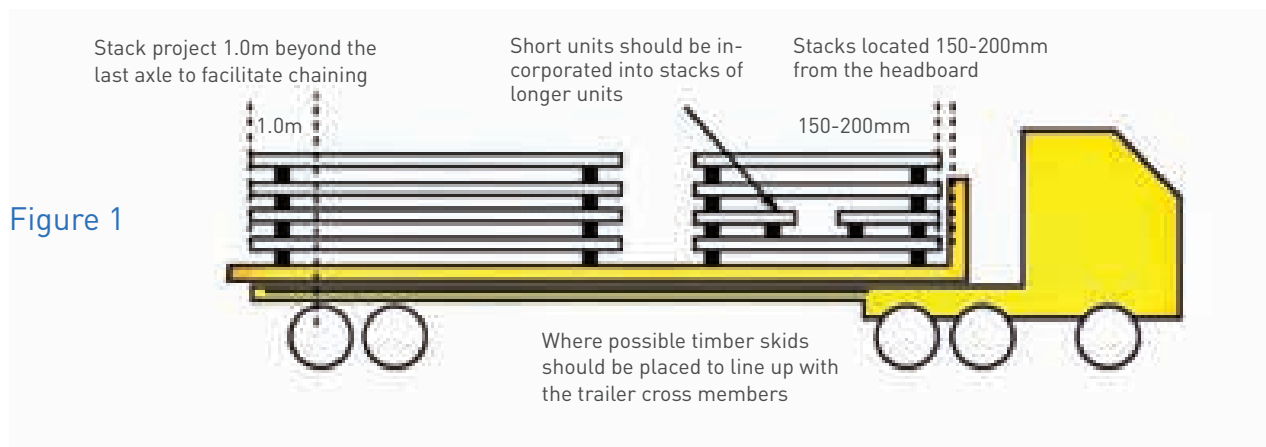

Figure 1

Stacking of Shorter Units

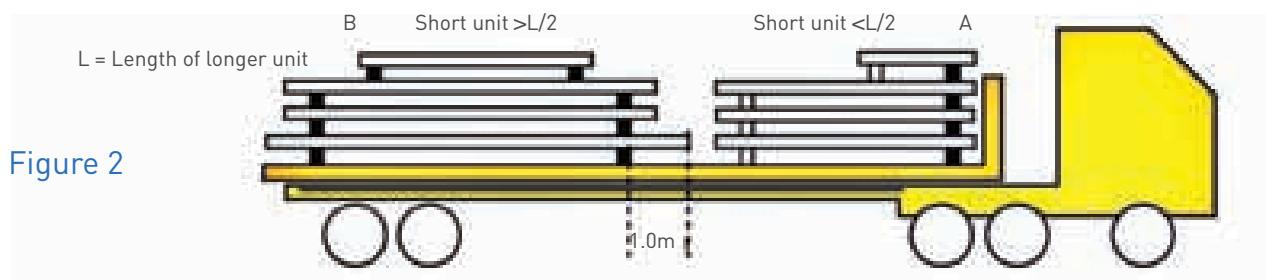

Figure 2

Projection beyond skid should not be more than 1.0m

Figure 2.1

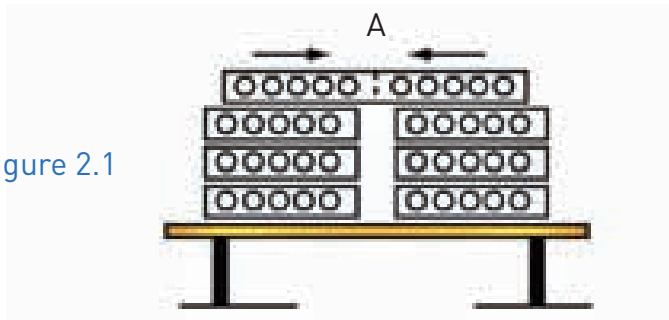
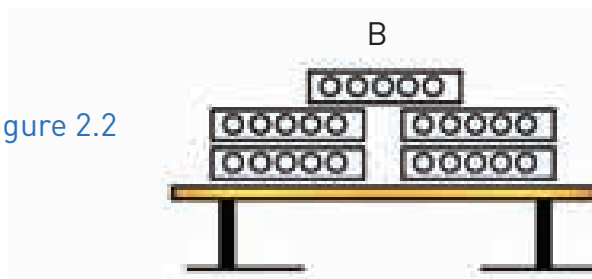

Figure 2.2



Offloading

In some cases a forklift is carried on the back of the vehicle for offloading material. The driver should ensure that the area is suitable for operating the forklift and he or she should be trained and certified to operate it.

In many cases offloading requires a crane. Care should be taken when attaching slings to either use the “lifting eyes” which have been designed into the beam or to ensure that the beam is not stressed or damaged as a result of lifting.

Product Safety

- Concrete beams may be abrasive; and
- Beams may have projecting steel.



Precast Concrete Delivery Risk Assessment

Precast Concrete Delivery	List All Trucks Used		
Vehicle Registration Number			
I will ensure that:			
The pre-start check has been carried out and documented. (Appendix 2).			
On-site traffic management and safety rules are followed.			
Flashing beacons are used on site or as required by Site Management.			
Appropriate PPE is worn on site.			
The truck is serviced and maintained as per the manufacturer's instructions.			
The truck is DOE tested annually.			
Defects are communicated to a responsible person.			
The surfaces of trailers are free from damage or defect likely to cause a load to shift or fall or to result in an accident to any person working on the trailer platform.			
Vehicles are not loaded beyond permitted maximum weights. (Appendix 3).			
Loads are evenly distributed across the trailer to ensure the vehicle remains stable at all times.			
Loading of Large Precast Products			
Loading is only carried out in a suitable location in the production area.			
Loading will comply with the legal axle weight requirements. (Appendix 3).			
The maximum width of overhanging load is 2.9 metres (9 feet 6 inches) and will not be exceeded.			
The maximum projection on either side of the vehicle is 305 millimetres (1.2 inches) and will not be exceeded.			
The length of load will not project more than 3 metres (10 feet) beyond the rearmost point of the vehicle.			

Precast Concrete Delivery

List All Trucks Used

Loading of Large Precast Products

A warning device is carried if the load projects more than 1 metre (3 feet 4 inches) beyond the back of the truck.

The route is checked to ensure that the height of the load will not strike low bridges or overhead cables.

Permits from any Local Authority/ies or Gardaí are obtained for loads outside allowable weights and dimensions prior to departure.

Loads are secured using chains, strapping and tensioners prior to leaving the yard.

Suitable protection against falls is provided if persons have to climb onto loads.

The load security is checked at suitable intervals during the road journey.

Offloading of Precast Products

The driver is trained and certified in the operation of a forklift if carried on the vehicle for offloading material.

The driver ensures that the offloading area is suitable for forklift operation.

Only certified/trained crane drivers unload large units.

Suitable protection against falls is provided if persons have to climb onto the load.

“Lifting eyes” if present in units are used for attachment of lifting slings/chains.

Additional Controls

Note: If a safety control measure is missing, indicate that on Your Action List on pages 112 and 113.



Section (k): Small Precast Products

Small Precast Products Risk Assessment

Small Precast Products	List All Trucks Used		
Vehicle Registration Number			
I will ensure that:			
The pre-start check has been carried out and documented. (Appendix 2).			
On-site traffic management and safety rules are followed.			
Flashing beacons are used on site or as required by Site Management.			
Appropriate PPE is worn on site.			
The truck is serviced and maintained as per the manufacturer's instructions.			
The truck is DOE tested annually.			
Defects are communicated to a responsible person.			
The surfaces of trailers are free from damage or defect likely to cause a load to shift or fall or to result in an accident to any person working on the trailer platform.			
Vehicles are not loaded beyond permitted maximum weights. (Appendix 3).			
Loads are evenly distributed across the trailer to ensure the vehicle remains stable at all times.			

Small Precast Products

List All Trucks Used

I will ensure that:

Individual pallets are secured to prevent products slipping and falling when in transit or during loading /offloading.

Pallets used to load and store products in transit are in good condition. Likewise Timber skids in order that they do not break or fall apart while in transit or in the course of movement.

Trailer platforms are cleaned after each offloading and free from debris which might cause loads to become unstable.

Sweeping brushes are provided in all vehicles for cleaning purposes.

Strapping and ties necessary to secure loads are provided for all vehicles and retained in good condition.

Loading of Small Precast Products

Loading is only carried out in a suitable location in the production area.

Loading will comply with the legal axle weight requirements. (Appendix 3).

The maximum width of an overhanging load of 2.9 metres (9 feet 6 inches) is not exceeded.

The maximum projection on either side of the vehicle of 305 millimetres (1.2 inches) is not exceeded.

The length of load will not project more than 3 metres (10 feet) beyond the rearmost point of the vehicle.

A warning device is carried if the load projects more than 1 metre (3 feet 4 inches) beyond the back of the truck.

The route is checked to ensure that the height of the load will not strike low bridges or overhead cables.

I will ensure that:			
Individual pallets are secured to prevent products slipping and falling when in transit or during loading /offloading.			
Pallets used to load and store products in transit are in good condition. Likewise Timber skids in order that they do not break or fall apart while in transit or in the course of movement.			
Trailer platforms are cleaned after each offloading and free from debris which might cause loads to become unstable.			
Sweeping brushes are provided in all vehicles for cleaning purposes.			
Strapping and ties necessary to secure loads are provided for all vehicles and retained in good condition.			
Loading of Small Precast Products			
Loading is only carried out in a suitable location in the production area.			
Loading will comply with the legal axle weight requirements. (Appendix 3).			
The maximum width of an overhanging load of 2.9 metres (9 feet 6 inches) is not exceeded.			
The maximum projection on either side of the vehicle of 305 millimetres (1.2 inches) is not exceeded.			
The length of load will not project more than 3 metres (10 feet) beyond the rearmost point of the vehicle.			
A warning device is carried if the load projects more than 1 metre (3 feet 4 inches) beyond the back of the truck.			
The route is checked to ensure that the height of the load will not strike low bridges or overhead cables.			



Small Precast Products

List All Trucks Used

Loading of Small Precast Products

Permits from Local Authority and An Garda Síochána are obtained for loads outside allowable weights and dimensions prior to departure.

Loads are secured using the chains, strapping and tensioners prior to leaving yard.

Suitable protection against falls is provided if persons have to climb onto loads, (eg. to attach chains/slings or tensioners).

Load security is checked during the journey.

Where product stacking is necessary that all parts of the load remain stable.

Where the vehicle is fitted with creels, these are properly fitted and secured during transit.

Loading of Mixed Loads

Individual pallets or lifts are secured and banded as necessary to avoid slips or falls during movement or transit.

Loads are balanced across the trailer platform to prevent the vehicle becoming unbalanced.

The layout of the load is planned to take account of the size and shape of non-standard products.

The layout of the load is planned to take account of the delivery schedule so as to ensure that the load remains stable until all deliveries have been completed.

Where necessary, employees reorganise a load after individual deliveries to ensure that vehicle stability is maintained.

Individual, non-standard products do not exceed the permitted maximum weights of either truck mounted cranes or demountable truck cranes.

List All Trucks Used			
Loading of Small Precast Products			
Permits from Local Authority and An Garda Síochána are obtained for loads outside allowable weights and dimensions prior to departure.			
Loads are secured using the chains, strapping and tensioners prior to leaving yard.			
Suitable protection against falls is provided if persons have to climb onto loads, (eg. to attach chains/slings or tensioners).			
Load security is checked during the journey.			
Where product stacking is necessary that all parts of the load remain stable.			
Where the vehicle is fitted with creels, these are properly fitted and secured during transit.			
Loading of Mixed Loads			
Individual pallets or lifts are secured and banded as necessary to avoid slips or falls during movement or transit.			
Loads are balanced across the trailer platform to prevent the vehicle becoming unbalanced.			
The layout of the load is planned to take account of the size and shape of non-standard products.			
The layout of the load is planned to take account of the delivery schedule so as to ensure that the load remains stable until all deliveries have been completed.			
Where necessary, employees reorganise a load after individual deliveries to ensure that vehicle stability is maintained.			
Individual, non-standard products do not exceed the permitted maximum weights of either truck mounted cranes or demountable truck cranes.			

Small Precast Products

List All Trucks Used

Loading of Mixed Loads

Individual non-standard products likely to become unstable while in transit unless loaded flat are loaded flat onto the trailer and that the load plan takes account of space requirements.

Only the driver is permitted to be present on the trailer during loading by the forklift truck

Loading of Full Loads of Standard Products

Loads are even and balanced across the trailer.

The trailer is loaded evenly so as to prevent the trailer tilting to one side during loading.

Where the load is to be offloaded using a truck mounted crane, sufficient space is left between stacks or pallets to facilitate the use of the grab.

Offloading of Precast Products

The driver is trained and certified in the operation of a forklift if carried on the vehicle for offloading material.

The driver ensures that the offloading area is suitable for forklift operation.

Only certified/trained crane drivers unload large units.

Suitable protection against falls is provided if persons have to climb onto the load (eg. to release/attach chains or slings and tensioners during offloading process).

“Lifting eyes” if present in units are used for attachment of lifting slings/chains.

Additional Controls

Note: If a safety control measure is missing, indicate that on Your Action List on pages 112 and 113.



Section (l): Demountable Forklift Trucks

Demountable (Truck Mounted) Forklift Truck: Safe System of Work

- Do not use the lift truck if you are not trained and authorised to do so;
- Do not operate the hydraulics when travelling;
- Never overload or use the lift truck outside its rated capacity;
- Never turn or travel with the load elevated;
- Never apply the forward tilt with a load;
- Never smoke in the vicinity of the lift truck;
- Do not lift people up on the forks of the lift truck;
- Take particular care on rough ground and especially on wet surfaces;
- Drive carefully and slowly, looking in the direction of travel. Sound horn at corners and obstructions; and
- Wear a safety belt if fitted, especially when operating on rough ground. The belt will restrain you in the vehicle in the event of a vehicle overturn.

Demountable Forklift Trucks Risk Assessment

Demountable Forklift Truck

List All Trucks Used

Vehicle Registration Number

I will ensure that:

Demountable forklifts are operated by competent personnel.

Demountable forklifts are inspected and certified every 12 months.

Demountable Forklift Truck

List All Trucks Used

I will ensure that:

Maximum prescribed weights will not be exceeded and account is taken of the reduction in maximum weight levels resulting from the use of any attachment, modification or non-standard device.

The mechanism for securing the forklift is checked daily and after the truck has been remounted to ensure that it is secured correctly and that the mechanism is free from defects.

Flashing beacons are used while on site or as required.

Loading and Offloading with Demountable Forklift Truck

The appropriate PPE is worn.

Care is taken to ensure that loads are balanced and stable before lifting to avoid slips and falls.

Passengers will not be carried on the vehicle.

The truck will only be used to load or offload products from its assigned vehicle and will not be used for any other purpose.

The driver checks the grab to ensure it is stable prior to offloading.

Additional Controls

Note: If a safety control measure is missing, indicate that on Your Action List on pages 112 and 113.



Section (m): Concrete Pipe Delivery Truck

Concrete Pipe Delivery Truck: Safe Systems of Work

Loading

The driver should ensure that:

- The appropriate PPE is worn;
- The load is uniformly distributed;
- The pipes are not overhanging the sides of the vehicle;
- The pipes have not been damaged during loading;
- The pipes are secured on the vehicle;
- Under no circumstances is the crane used for lifting personnel; and
- The vehicle is never moved with the crane in the raised position.

Load Security

Pipes 225–900 mm diameter:

- Pipes can be loaded in layers, maximum of three layers;
- Sufficient wedges of size min. 150 mm x 100 mm used to choke pipes;
- Web strapping through each layer fore and aft with double scotches; and
- Individual pipes on top layer roped down.



Pipes 1050–1350 mm diameter:

- Individual pipes secured with webbing strap;
- Protection between pipe and strap;
- Every socket chocked with 150 mm x 100 mm wedge; and
- Where practical the load should be in contact with the headboard (i.e. pipes should have a timber scotch at the base of the headwall).



Pipes 1500–2400 mm diameter:

- Individual pipes to have a minimum of double webbing straps, fore and aft; and
- Chocked with suitably sized wedges fore and aft of individual pipes (i.e. four wedges per pipe).



Offloading

Note: The driver should be familiar with the details provided in the safety data sheet on handling and stacking pipes.

The driver must ensure that:

- The appropriate PPE is worn;
- The site traffic management system is observed;
- He/she checks with the Site Manager or Supervisor and obtains clear instructions on the exact location where the pipes should be offloaded;
- A visual check is carried out to ensure the area where the pipes are being stacked is suitable and has adequate load bearing capacity;
- Pipes are placed well back from the edge of any excavation and at right angles to it to prevent pipes rolling into the trench;
- Pipes in storage are safely chocked;
- There are no overhead power cables in the unloading area. Under no circumstances should the crane be operated within 6 metres (20 feet) of 200Kv overhead power cables, within 4.5 metres (15 feet) of 100Kv cables or within 3 metres (10 feet) of all other lines;
- He/she never attempts to lift pipes the weight of which exceeds the safe working load of the crane;
- If working on or near public roads, traffic lanes are adequately protected by the contractor;
- The vehicle is positioned as close as possible to where the pipes are to be offloaded, both stabilisers are extended and stabiliser pads are fitted underneath the legs;
- The operating position for the crane is accessed safely using the ladders and steps provided;
- There are no personnel within the working area of the crane. If necessary, assistance should be requested from the Site Manager or Supervisor;
- When the offloading is complete, the crane is stowed safely, the stabilisers are retracted and the stabiliser pads are stowed;
- Under no circumstances is the crane used for lifting personnel; and
- The vehicle is never moved with the crane in the raised position.

Stacking Heights: The following maximum stacking heights should not be exceeded:

Diameter (mm)	No. of Layers
Up to 300	6
300–375	4
450–600	3
675–975	2
1000 +	1

Blocks, Tiles, Pipes, Precast

Drivers should return all rejected material to the depot from which it was dispatched.

Concrete Pipe Delivery Truck Risk Assessment

Concrete Pipe Delivery Truck	List All Trucks Used		
Vehicle Registration Number			
I will ensure that:			
The pre-start check has been carried out and documented. (Appendix 2).			
The crane is free from hydraulic leaks.			
Hydraulic unions are checked for damage.			
Check valves are fitted and operational.			
The access ladder to the controls is in good order.			
The truck has not been unevenly loaded or overloaded.			
Loading/unloading only takes place on stable/level ground.			
The driver extends both stabilisers on boards before starting any offloading.			
Only trained and competent drivers will operate the truck mounted crane.			
No loading/unloading takes place within 6 metres (20 feet) of 200Kv overhead power cables, within 4.5 metres (15 feet) of 100Kv cables or within 3 metres (10 feet) of all other lines.			
No unloading takes place close to personnel.			
The pipes do not overhang the side of the truck.			
The concrete pipes are secure on the truck body.			
None of the pipes are damaged during loading / unloading.			

Concrete Pipe Delivery Truck

List All Trucks Used

I will ensure that:

Reversing cameras are fitted and operational.

On-site traffic management and safety rules are followed.

Flashing beacons are used while on site or as required.

Appropriate PPE is worn.

The truck is maintained as per the manufacturer's instructions.

Where used on a public road, the truck is DOE tested annually.

The crane is tested annually by a competent person.

Defects are communicated to a responsible person.

Safety Practices

Drivers never work under a raised crane unless mechanically propped.

Drivers never drive with the crane in the raised position.

Drivers never operate the crane near or under power lines.

Only competent/licensed personnel drive and operate trucks.

The ground conditions are assessed before loading/unloading.

Drivers never use the crane to lift personnel.

Additional Controls

Note: If a safety control measure is missing, indicate that on Your Action List on pages 112 and 113.



Section (n): Low Loader Truck

Low Loader (Plant Carrier) Truck Safe System of Work

The transport of plant and equipment such as road rollers, excavators, black top layers and other equipment usually requires specialised trailers with loading ramps, anchor points and low profile body.

Companies should ensure that:

- The gross vehicle weights as specified in Appendix 3 are not exceeded;
- If the gross weight or dimensions are exceeded, special permits are obtained from An Garda Síochána and the Local Authority/ies through whose area/s the equipment will be transported; and
- Chains should be provided for securing the equipment and the restraint equipment checked for damage, wear and tear and rated for the load it is restraining.

Load Securing Guidelines

- The front and rear wheels of the equipment should be butted against the bulkhead or against chocks which are secured;
- Lashing chains from the front and rear towing eyes or axles should be secured and tensioned to anchorage points on the trailer;
- Trailer flaps (beaver tails) should be secured in the upright position; and
- The load should be checked after the first kilometre of the journey and at regular intervals throughout the journey.

Vehicle Height

- The driver must check the overall height of the vehicle when the plant and machinery is loaded to ensure that it can safely pass under any bridges along the route. He/she should check the Iarnród Éireann Railway Bridge Map to find out if there are any low bridges on route.



Low Loader Truck Risk Assessment

Low Loader Truck

List All Trucks Used

Vehicle Registration Number

I will ensure that:

The pre-start check has been carried out and documented. (Appendix 2).

Only trained and competent drivers will operate the truck.

The design and construction of the vehicle is suitable for the load.

The maximum expected floor loading is ascertained to ensure that the floor and supporting members are adequate.

The load is arranged not to obstruct the driver's field of vision, including rearward vision through the driving mirrors.

The driver knows the exact height of the load and the width of the load at that height.

On-site traffic management and safety rules are followed.

Load Height

Loading will comply with the legal axle weight requirements. (Appendix 3).

The maximum width of overhanging load of 2.9 metres (9 feet 6 inches) is not exceeded.

Low Loader Truck

List All Trucks Used

Load Height:

The maximum projection on either side of vehicle of 305 millimetres (1.2 inches) is not exceeded.

The length of the load will not project more than 3 metres (10 feet) beyond the rearmost point of the vehicle.

A warning device is carried if the load projects more than 1 metre (3 feet 4 inches) beyond the back of the truck.

The route is checked to ensure that the height of the load will not strike low bridges or overhead cables.

Permits from An Garda Síochána and Local Authority/ies are obtained prior to departure for loads outside allowable weights and dimensions.

Loads are secured using chains, strapping and tensioners prior to leaving the yard.

Suitable protection against falls is provided (eg. if persons have to climb onto loads to attach chains/slings or tensioners).

Load security is checked during the journey.

Loading

The transporter wheels are chocked at the front and rear.

The ramp, tyres of the machine and trailer bed are free from oil, grease, ice etc so that the machinery cannot slip.

The loading area is sufficiently large to accommodate the movement of the machine without striking obstructions or causing hazards to others.

The transporter is on firm and level ground and correctly positioned with its brakes applied.

Low Loader Truck

List All Trucks Used

Loading:

All ramps are secure and long enough to keep the ramp angle low.

All persons stand clear of vehicles being loaded.

The machine to be loaded is lined up with the ramps so no turning is necessary.

Loading is carried out at the slowest possible speed, particularly at any point of balance.

Any necessary movement of the machine whilst on the transporter is minimised and carefully executed.

To achieve maximum stability the load is placed so that the centre of gravity is as low as possible, and near to the vehicle longitudinal centreline. (Loads with a high centre of gravity should only be transported on vehicles with a low platform height).

The machine is securely lashed down in position, the brakes engaged and any other necessary precautions are taken to ensure that the machine cannot change position during transit.

When the machine has been stowed and the engine stopped, the pressure in the hydraulic system is relieved by moving all of the control levers through all their positions.

Objects are not left loose in the operator's cab of the plant being carried.

The clearance between the undersides of low loading vehicles and the road surface is checked before moving off.

Ramps are secured in the stored position following loading.

Additional Controls

Note: If a safety control measure is missing, indicate that on Your Action List on pages 112 and 113.

Record of Implementation

This Code of Practice
has been completed by:

Date:

The controls to be used as per this Code of Practice have been brought to my attention:

Signed by drivers: (1)

Name :

Address:

..... Phone:

(2)

Name :

Address:

..... Phone:

(3)

Name :

Address:

..... Phone:

Note:

The list of hazards and controls given is not exhaustive and is in no particular order.

Where unusual circumstances arise additional risks may need consideration; risks must be assessed and additional controls set out.

Contact your Supervisor where necessary.

IF IT'S NOT SAFE DON'T DO IT AND INFORM MANAGEMENT

My Vehicle Safety Action List

Where your assessments have indicated safety controls that are missing, list below what action you will take to put that control in place. This action should have a date for completion. When the control is in place, the action should be signed off and the risk assessment changed to show that the control is now in place.

Risk Assessment	Safety Control Measures that are missing	Action that I must take on my vehicle	Date	Sign
Example: Concrete Mixer	Flashing Beacon is not working	Fit new bulb in flashing beacon	01/05/12	Joe Rock

Risk Assessment	Safety Control Measures that are missing	Action that I must take on my vehicle	Date	Sign

Appendix 1

Driving Periods, Breaks and Rest Periods

1. Driving without a break

The maximum period of driving without a break is 4.5 hours, after which a break of 45 minutes must be taken. This break may be replaced by one break of at least 15 minutes and a second break of at least 30 minutes, distributed over the driving period in such a way that a cumulative break of at least 45 minutes has been taken during 4.5 hours driving.

Note: A driver may not carry out other work such as offloading during his or her break.

2. Daily driving period

The daily driving period must not exceed 9 hours, which may be extended twice in any week to 10 hours.

3. Weekly driving period

A driver can work a maximum of 6 driving periods in a week. The total driving time if he or she works 6 periods must not exceed 56 hours.

4. Fortnightly driving

The total period of driving in any one fortnight must not exceed 90 hours.

5. Daily rest

In each period of 24 hours a driver must have a daily rest of at least 11 consecutive hours, which may be reduced to not less than 9 consecutive hours not more than 3 times in any one week.

6. Weekly rest

During each week, a driver must take a weekly rest no later than at the end of six 24 hour periods from the end of the previous weekly rest period. The rest period taken may be either:

- A regular rest period of at least 45 hours; or
- A reduced weekly rest period of between 24 and 45 hours.

In any two consecutive weeks, a driver must take either:

- Two regular weekly rest periods; or
- One regular rest period and a reduced rest period.

If a reduced rest period is taken, compensation for the remaining hours must be taken before the end of the third week after the week the reduced rest was taken. The compensation could also be attached to another rest period of at least 9 hours.

Appendix 2

Vehicle Controls and Daily Pre-Start Checking

VEHICLE CONTROLS & DAILY PRE-START CHECKING INSPECTION SHEET

Vehicle Make & Model:..... Driver's Name:.....

Reg. No..... Week Commencing:.....

Odometer Reading Start:..... Odometer Reading Finish:.....

Inspection Item & Description	Mon	Tues	Wed	Thur	Fri	Sat	Sun
Tractor Unit External Features:							
Exhaust securely fitted & free from leaks.							
Unit sitting straight & level.							
No visible signs of external damage to tractor & tanker unit.							
No visible signs of fluid/oil leaks under the vehicle or on other parts of the vehicle.							
All lights present and operating.							
Tyres:							
<ul style="list-style-type: none"> • Correctly inflated; • Free from defects; • Correct thread depths; and • Wheel nuts present and suitably tightened. 							
Trailer securely coupled to tractor unit.							
Number plates & reflectors fitted & clearly visible.							
Windows & rear-view mirrors free from defects & grime & provide clear vision. Mirrors adjusted appropriately before moving off.							

Inspection Item & Description	Mon	Tues	Wed	Thurs	Fri	Sat	Sun
Tractor Unit External Features:							
Fluid levels correct: steering, brake, hydraulic & engine oil; coolant; windscreen washer; auto greaser.							
Fuel adequate in diesel tank.							
Climbing & descending handholds & footplates in good condition.							
Loading/unloading equipment (including hydraulic rams) in good working order.							
Internal Features:							
No loose objects in the cab.							
Cab doors close securely.							
Seating & safety belt in good order.							
Wipers and horn operating.							
No excessive steering lock applied.							
Adequate build up of air pressure.							
No warning lights flashing on dashboard.							
Tacograph working – new tachograph chart or personal card inserted.							
Warning triangle in cab.							
Reversing camera (where fitted) is operational.							
A fire extinguisher is fitted in the cab.							
First-aid box available and stocked in the vehicle cab.							
ESB warning signs fitted to the truck (overhead lines).							
Date	Description of Defect			Completion Date	Managers Initials		
Driver's Signature:				Date:			
Manager's Signature:				Date:			

Appendix 3

(These are subject to change - check www.transport.ie for updates)

Vehicle Weights and Dimensions

Maximum Weight Laden – Rigid Trucks

THE MAXIMUM WEIGHT LADEN OF A TWO AXLE RIGID TRUCK



AXLE SPACING	MAXIMUM WEIGHT LADEN
Less than 3 m	16t
Not less than 3 m	18t

THE MAXIMUM WEIGHT LADEN OF A THREE AXLE RIGID TRUCK



THE MAXIMUM WEIGHT LADEN OF A THREE AXLE RIGID TRUCK IS 25t
Subject to 5.5 tonnes per metre of axle spacing "X".

THE MAXIMUM WEIGHT LADEN OF A THREE AXLE RIGID TRUCK WITH TWIN TYRES AND ROAD FRIENDLY SUSPENSION* ON EACH DRIVING AXLE IS 26t.

Subject to 5.5 tonnes per metre of axle spacing "X".

*"Road friendly suspension" means air suspension or the equivalent thereof as defined in Annex II to Directive 96/53/EC. Double – drive axles, where neither axle exceeds 9.5t, are also regarded as road friendly.

THE MAXIMUM WEIGHT LADEN OF A RIGID TRUCK HAVING A TOTAL OF 4 AXLES



THE MAXIMUM WEIGHT LADEN OF A FOUR AXLE RIGID TRUCK IS 30t.

Subject to 5 tonnes per metre of axle spacing "X".

THE MAXIMUM WEIGHT LADEN OF A FOUR AXLE RIGID TRUCK WITH TWIN TYRES AND ROAD FRIENDLY SUSPENSION* ON EACH DRIVING AXLE IS 32t.

Subject to 5 tonnes per metre of axle spacing "X".

* "Road friendly suspension" means air suspension or the equivalent thereof as defined in Annex II to Directive 96/53/EC. Double-drive axles, where neither axle exceeds 9.5t, are also regarded as road friendly.

Maximum Weight Laden – Tractor Units

THE MAXIMUM WEIGHT LADEN OF A TWO AXLE TRACTOR UNIT



AXLE SPACING	MAXIMUM WEIGHT LADEN
Less than 3 metres	16t
3 metres or more	18t

THE MAXIMUM WEIGHT LADEN OF A THREE AXLE TRACTOR UNIT

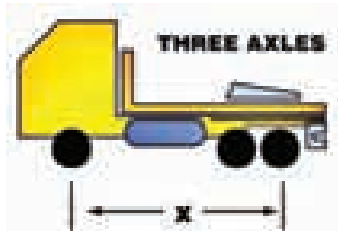

THE MAXIMUM WEIGHT LADEN OF A THREE AXLE TRACTOR UNIT IS 25t.

Subject to 6 tonnes per metre of axle spacing "X".

THE MAXIMUM WEIGHT LADEN OF A THREE AXLE TRACTOR UNIT WITH TWIN TYRES AND ROAD FRIENDLY SUSPENSION* ON EACH DRIVING AXLE IS 26t.

Subject to 6 tonnes per metre of axle spacing "X".

* "Road friendly suspension" means air suspension or the equivalent thereof as defined in Annex II to Directive 96/53/EC. Double-drive axles, where neither axle exceeds 9.5t, are also regarded as road friendly.

Maximum Weight Laden –Articulated Vehicle: in Relation to the Semi-Trailer Length

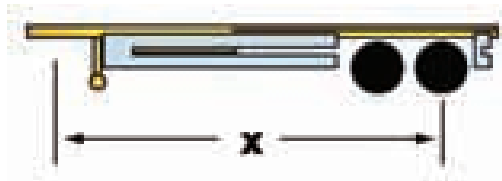

The weight laden, expressed in tonnes, of an articulated vehicle must not exceed the number obtained when the distance between the king-pin and the centre of the rearmost axle, expressed in metres correct to one decimal place, is multiplied by 5.5.

ARTICULATED VEHICLES HAVING 5 AXLES – TWO AXLE TRACTOR UNIT

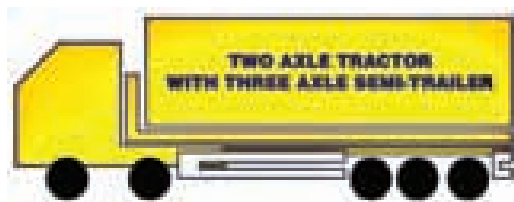

UNTIL 1 JANUARY 2010 (and subject to further review), THE MAXIMUM WEIGHT LADEN FOR AN ARTICULATED VEHICLE CONSISTING OF A TWO AXLE TRACTOR UNIT WITH A THREE AXLE SEMI-TRAILER WAS 42t.

Subject to 5.5 tonnes per metre of distance between the king-pin and the centre of the rear axle.

THE MAXIMUM WEIGHT LADEN FOR SUCH A VEHICLE AFTER THAT DATE IS 40t.

ARTICULATED VEHICLES HAVING 5 AXLES – THREE AXLE TRACTOR UNIT



THE MAXIMUM WEIGHT LADEN FOR AN ARTICULATED VEHICLE HAVING A TOTAL OF FIVE AXLES BEING A THREE AXLE TRACTOR UNIT WITH A TWO AXLE SEMI-TRAILER IS 40t.

Subject to 5.5 tonnes per metre of distance between the king-pin and the centre of the rear axle.

THE MAXIMUM WEIGHT LADEN FOR A COMBINATION OF AN APPROPRIATE MOTOR VEHICLE* WITH A TWO AXLE SEMI-TRAILER IS 42t.

*"An Appropriate Motor Vehicle" is a mechanically propelled vehicle with at least three axles, twin tyres, air suspension or an equivalent suspension on each driving axle and ABS brakes.

ARTICULATED VEHICLES HAVING A TOTAL OF SIX OR MORE AXLES

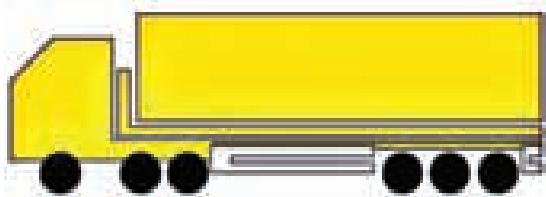

THE MAXIMUM WEIGHT LADEN FOR AN ARTICULATED VEHICLE HAVING A TOTAL OF SIX OR MORE AXLES IS 40t.

Subject to 5.5 tonnes per metre of distance between the king-pin and the centre of the rear axle.

THE MAXIMUM WEIGHT LADEN FOR A COMBINATION OF AN APPROPRIATE MOTOR VEHICLE* WITH A 3 AXLE SEMI-TRAILER IS 44t.

*"An Appropriate Motor Vehicle" is a mechanically propelled vehicle with at least three axles, twin tyres, air suspension or an equivalent suspension on each driving axle and ABS brakes.

Source: Road Safety Authority, *Leaflet No 1, Guidelines on Maximum Weight and Dimensions of Mechanically Propelled Vehicles and Trailers.*

Appendix 4

Emergency Procedures

Emergency Breakdown Procedure

Prior to Driving

- Keep contact details in your mobile or in writing of the breakdown firm your organisation uses and any reference numbers you need to quote;
- Ensure you have a fully charged mobile phone prior to driving to summon help if necessary. DO NOT use the phone whilst driving.

In the Event of a Breakdown

- Consider your own safety first;
- If on a national route:
 - o Get your vehicle off the road if possible. Pull onto the hard shoulder;
 - o Warn other road users by using your hazard lights, especially if your vehicle is causing an obstruction. Stop as far to the left as possible with your wheels turned to the left;
 - o Keep your side lights on if it is dark or visibility is poor.
- Prior to leaving the vehicle, wear/put on a high visibility jacket or vest;
- Leave the vehicle through a left hand door and get off the road. If you are reluctant or can't get out of the vehicle, stay in the vehicle but keep your safety belt on. Turn the vehicle wheels to the left;
- If safe to do so, place a warning triangle on the road behind your vehicle on the same side of the road. Always take great care when placing them;
- Do not stand or let anybody else stand between your vehicle and oncoming traffic. At night or in poor visibility do not stand where you will prevent other road users seeing your lights;
- Do not use mobile phones at or near petrol spillage or fumes;
- Inform the appropriate recovery service of the situation or contact the emergency services:
 - o Give them clear instructions on your location: road number, general location, direction of travel, specific local landmarks;

Appendices continued

- o Inform them of your vehicle type, colour and registration number, and of how many persons are in the vehicle and any indication of the cause of the breakdown;
- o Contact your destination or nominated contact person to inform them of the situation;
- o Do not attempt to remedy anything other than the simplest problem.
- If you breakdown in an urban area, stay in the vehicle with the doors locked until help arrives;
- When help arrives ask for proof of identity.

In the Event of a Breakdown on a Motorway

- Try to leave the motorway at the nearest exit or pull into a rest area. If this is not possible, use your indicators or hazard warning lights and pull onto the hard shoulder. Try and stop near an emergency telephone;
- Prior to leaving the vehicle, wear/put on a high visibility jacket or vest. Leave your vehicle by the left hand doors. Do not cross the carriageway;
- In general do not use warning triangles on motorways as this may put you in danger from oncoming traffic;
- Leave your vehicle on the hard shoulder as far to the left as possible, maximising the gap between the carriageway and the vehicle. If possible exit the vehicle via the passenger side door and move away from the vehicle, up the grass verge if present, and wait at a safe distance from the carriageway. The safest place to wait is upstream of the traffic relative to the vehicle (so that the vehicle is to the left of you when you face the carriageway). Contact the Gardaí using an emergency phone or a mobile when it is safe to do so.

Emergency Procedure in the Event of a Vehicle Fire

In the event of a fire, however small, an emergency evacuation of the vehicle must be conducted. Take the following steps:

- Consider your own safety first;
- Get your vehicle off the road, or out and away from any bridge or tunnel if possible. Pull onto the hard shoulder;
- Consider the best way to get off and away from the vehicle, this will depend on the nature of the incident, the passengers, the type of vehicle and your location. If possible, people should exit the vehicle as they would normally. Care should be taken of approaching traffic;
- Do not attempt to tackle vehicle fires unless trained to do so. Under bonnet fires should not be tackled but left to the Fire Brigade.

Appendices

Appendix 5

Incident Recording Form

DETAILS OF INCIDENT

Location of incident

Driver

Vehicle

Date

Time

Type of Incident
(Tick ✓)

Road Vehicle Collision

Product Spillage

Site Accident

Near Miss

Lost Load

Speed Limit (km/hr)

Your Speed (Km/hr)

Weather Conditions

Road Conditions

Road Signs

Garda Details

Was there a Garda present?

When did the Garda arrive at the scene?

Name of the Garda present.

Appendices continued

Rank, Number and Station of the Garda.

Details of Any Other Vehicle(s) Involved in the Incident

Make of Vehicle

Model of Vehicle

Registration Number of the Other Vehicle

Name of Owner

Name of Driver

Address of Other Driver

Telephone Number of Driver

Insurance Company

Policy Number

Description of Damage
to the Other Vehicle(s)

(Include photograph if available)

Appendices

Details of Damage to Other Property (if any)

Type of Property

Name of Owner

Address of Owner

Description of Damage
(Include photograph if available)

Lost Load/Product Spillage/Contamination Details

Product Type?

Quantity Spilled/Amount Lost?

How Contaminated?

Injury Details

Was anyone injured?

Was an ambulance called?

Name of the injured person.

Address of the injured person.

Appendices continued

Was a safety belt worn?

Description of injury.

Witness Details (if any)

Name of Witness

Address

Telephone Number

Brief Description of the Incident

Appendices

Incident Sketch

(Include photograph if available)

Any remedial action
taken at the incident scene?

Photographs taken?

Driver Signature

Date

Follow-up (to be completed by the Driver's Manager/Supervisor)

Has the driver the correct licence for the vehicle?

Has the driver received the correct training for the vehicle?

Has the driver received instruction, information and training (as appropriate) in relation to safe methods of work?

Was the incident caused by:
(tick ✓ the correct option)

- Human error?
- Mechanical failure?
- Unsafe systems of work?
- Road/weather conditions?
- Other?

Was the driver to blame in any way because of:
(tick ✓ the correct option)

- Carelessness?
- Dangerous driving?
- Loss of concentration?
- Misjudgement?
- Not following safe systems of work?
- Unfamiliar with the vehicle?
- Other?

Was the incident avoidable?

Does the Health & Safety Authority
need to be notified at www.hsa.ie?

Appendices

Date of notification.

Remedial action required.

Name of person carrying out the action.

Date by which the action will be carried out.

Signed: Date:

Details of Actions Completed

Date action completed.

Comments:

Signed: Date:

Appendix 6

Sources of Further Information/Useful Websites

Association of Lorry Loader Manufacturers and Importers	www.allmitraining.co.uk
Attorney General (Legislation)	www.attorneygeneral.ie
Mineral Products Association	www.cementindustry.co.uk
Concrete Block Association	www.cba-blocks.org.uk
Concrete Pipeline Systems Association	www.concretepipes.co.uk
Department of Transport	www.transport.ie
Department for Transport (UK)	www.dft.gov.uk
Electricity Supply Board	www.esb.ie
Environmental Protection Agency	www.epa.ie
Health and Safety Authority	www.hsa.ie
Health and Safety Executive (UK)	www.hse.gov.uk
Institute of Occupational Safety and Health	www.iosh.org.uk
Institute of Road Transport Engineers	www.soe.org.uk
Irish Rail	www.irishrail.ie
National Roads Authority	www.nra.ie
National Standards Authority of Ireland	www.nsai.ie
Refined Bitumen Association	www.bitumenuk.com
Road Safety Authority	www.rsa.ie
The Royal Society for the Prevention of Accidents (RoSPA)	www.rospace.com/RoadSafety/
United Nations Economic Committee for Europe (ADR)	www.unece.org/trans/danger/publi/adr

*Working to
create a
National Culture
where All Commit to
Safe and Healthy
Workplaces and the Safe
and Sustainable
Management of
Chemicals*

**HEALTH AND SAFETY
AUTHORITY**

Tel. 1890 289 389

International
Callers

00353 1 6147000

Fax. (01) 6147020

www.hsa.ie



**HEALTH AND SAFETY
AUTHORITY**